



Cape Horn Extreme 330R-Remote

Installation and Operating Manual



Spectra Watermakers
Katadyn Desalination LLC.
2220 S. McDowell Blvd Ext. Petaluma, CA 94954
Phone: 415-526-2780
www.spectrawatermakers.com
Updated January 2024



Table of Contents

Getting Started	4
Installation	7
Introduction to the Cape Horn Extreme 330	8
Installation Basics.....	9
Components.....	10
Cape Horn Extreme Plumbing Layout.....	12
Product Water Plumbing and Pressure Gauge Tube Installation	13
Cape Horn Extreme Remote System Wiring	14
Optional Z-Ion Protection System and Installation.....	16
Optional Tank Switch	17
New System Start Up	19
New System Start up and Testing Freshwater on Dock.....	20
New System Start up and Testing in Ocean.....	21
Operation	22
Normal Operation and Fresh Water Flush.....	23
Dry Testing with an Artificial Ocean.....	24
Spectra Manual Remote Controller Guide	25
Adjusting Freshwater Flush Duration	26
Suggested Spares	27
Maintenance, Storage & Troubleshooting	28
Maintenance	29
Cape Horn Extreme Plumbing Diagram	31
Cape Horn Extreme Electrical Diagram.....	32
Cape Horn Extreme Electrical Specifications.....	35
Introduction to Spectra Chemicals	36
Cape Horn Storage Procedure	38
Winterizing with Propylene Glycol	39
Membrane Cleaning Procedure.....	40
Flow Test	41
Troubleshooting	43
Technical Bulletins.....	46
Parts Identification	54
Owner Resources & Warranty	62
Product Registration, Installation & Commissioning Reports	63

Getting Started and Manual Overview

Description of the pictograms

The following symbols will be used in the manual to highlight important indications and warnings:



ATTENTION:

This symbol indicates accident prevention for the operator and / or for any exposed persons.



CAUTION:

This symbol indicates that there is the possibility of damaging the system and / or its components.



DANGER:

This symbol indicates a shock hazard or exposure to risk.



NOTE:

This symbol indicates useful information.



ATTENTION

Important Information Safety Warnings

To safeguard the operator's safety and to avoid possible damage to the machine, before carrying out any operation on the machine, it is essential to read carefully all the instructions manual. Check periodically that no leaks are present. Avoid installing the plant where a leak may cause damage and/or jeopardize the safety of the vessel.

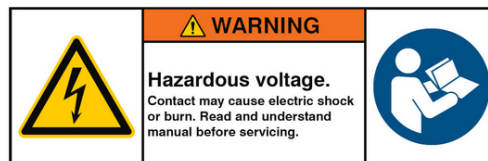
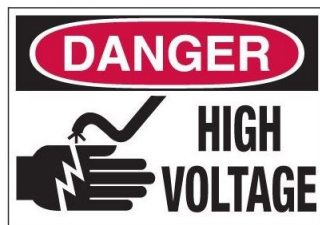

Unpack the system and inspect it for damage during shipping. Freight damage must be reported within 24 hours. Refer to the shipping list for your system to ensure you received all of the components listed. Do not discard any packaging until you have found and identified all of the parts. The small installation parts are listed on the kit list.

Be aware of the caution and warning signage on the system. If box is labeled “Heavy”, please use two people when moving.



ATTENTION

Important Information Safety Warning Cont.

Study the system layout diagram, component photos, and descriptions before beginning installation.



CAUTION: We will not be held responsible for shortages and or freight damage that are not reported within thirty days of the ship date.

Lay out the system. Before starting the installation identify where each module and component will be placed. Insure that there is enough clearance around the components for removal of filters and system service. Make sure you have adequate tubing and hose before starting. Additional parts may be ordered.



DANGER/CAUTION:

Do not use system in ports or polluted seaways.

Cape Horn Extreme 330 Remote Manual Shipping List:



ATTENTION: Please read any warning labels in packaged materials which may include SDS sheets and further documents.

- Cape Horn 330 Remote Manual kit (includes Control Box and Remote Control)
- Accumulator Assembly
- Flowmeter and Pressure Gauge Assembly
- High pressure Clark Pump with membrane pressure vessel
- Black high pressure prefilter with 5 micron filter
- Feed Pump Module Assembly with fresh water flush module
- Remote Manual install kit with black product water tubing
- Service kit
- Two lengths 5/8" Hose (25')

Optional: Z-Ion Copper Ionization Flush System Upgrade

Installation

Introduction to the Cape Horn Xtreme Remote Manual

The Cape Horn Xtreme Remote Manual is designed to be efficient, simple, and durable. Properly installed and maintained it will supply years of reliable service. Prudent operation is required with any marine equipment. ***Always maintain enough reserve water to get safely into your next port.***

The Spectra Intensifier, known as the Clark Pump, was introduced in 1997 and has continually improved since. It is built of modern non-corrosive composites and comes with a 40" (101.6 CM) high rejection membrane. The Clark Pump and membrane module are pre-mounted and plumbed together as a single unit to save time and add reliability.

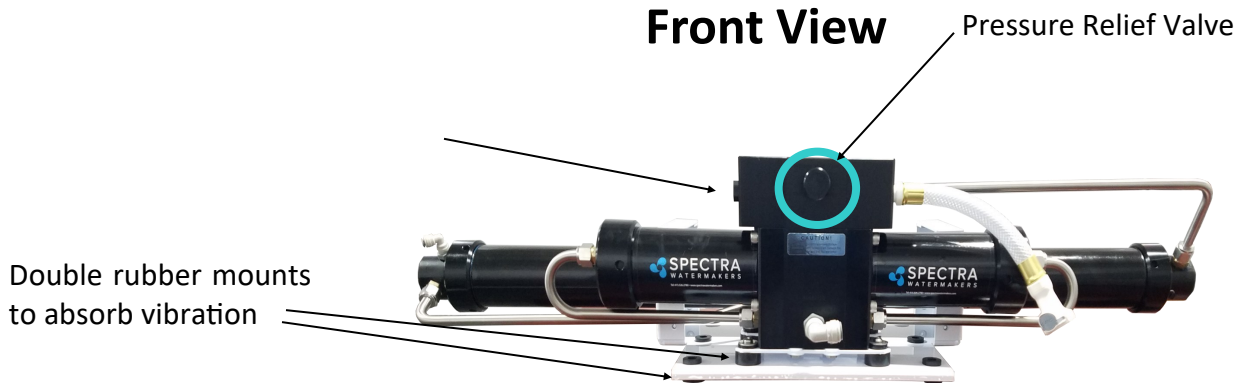

Feed Pump Module A:

Includes primary feed pump, switch, cooling fan, charcoal filter, flush valve, service valve, and service port. The module has compact and streamlined plumbing. The cooling fan increases longevity.

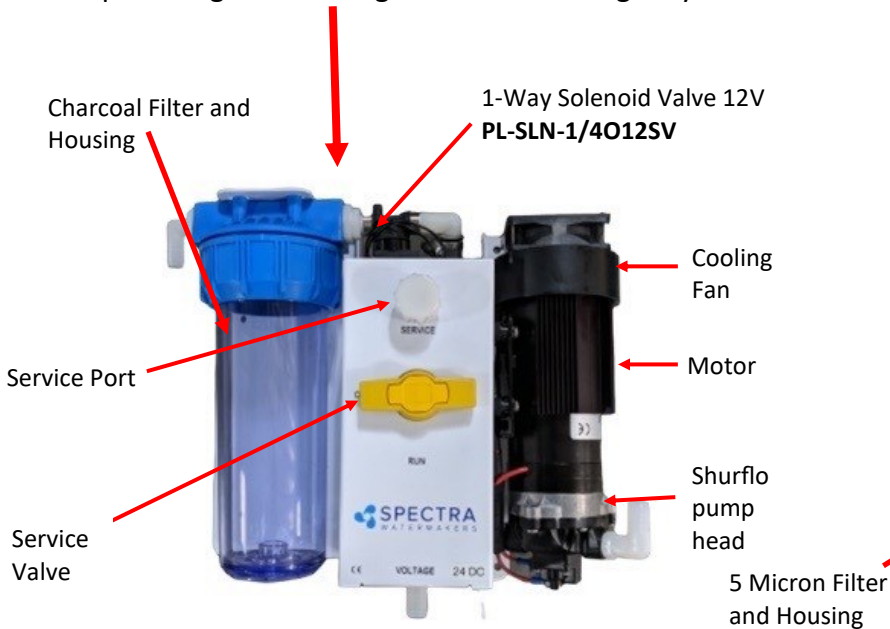

Feed Pump Module B:

Includes secondary feed pump (same as in module A), 5 micron filter housing, and power switch.

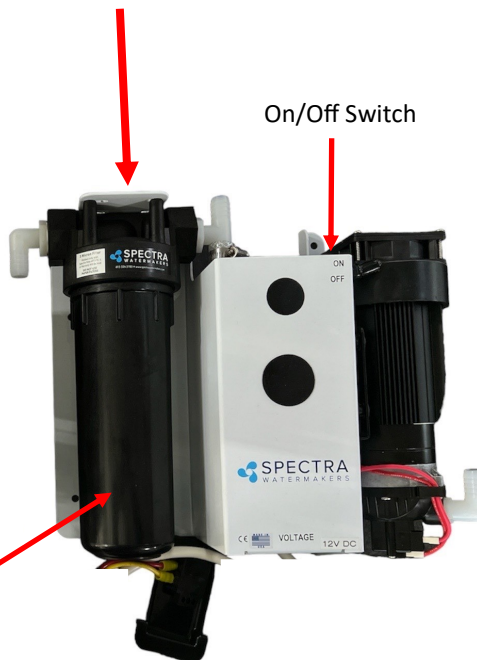

NOTE: If your system came with the optional Z-Ion, the Z-Ion unit will replace the charcoal filter housing. The photo above, and all subsequent photos of the Feed Pump Module, will look slightly different.

Installation Basics

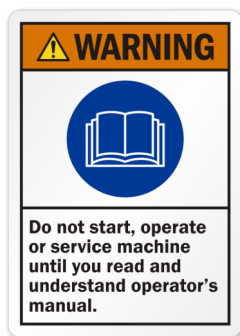

Important Installation Notes

- Avoid tight hose bends and excessive runs.
- Use heavy gauge wire.
- Install feed pump module as low as possible.
- Use a dedicated thru-hull with scoop type strainer.
- Do not mount components over electrical devices.

*Thru-hull
Not Supplied.*

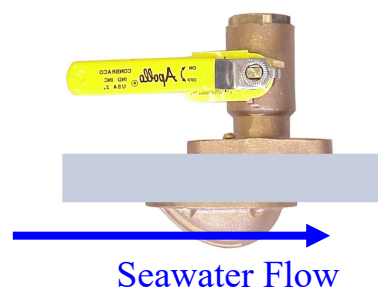

CAUTION: Avoid getting dirt or debris into the piping or hoses during assembly. A small bit of debris can stop the system!

Thru-hull Location: The system must be connected to a dedicated 1/2" to 3/4" forward facing scoop-type intake thru-hull and seacock.

Install the thru-hull intake as far below the waterline and as close to centerline as possible to avoid contamination and air entering the system. Do not install the intake close to, or downstream of, a head discharge, behind the keel, stabilizer fins, or other underwater fixtures.

Thru-hulls in the bow area are susceptible to air intake in rough conditions. Sharing a thru-hull can introduce unforeseen problems such as intermittent flow restrictions, air bubbles, contaminants, and will void the warranty. For racing boats and high speed boats traveling above 15 knots, a retractable snorkel-type thru-hull fitting is preferred because it picks up water away from the hull.

The brine discharge thru-hull should be mounted above the waterline, along or just above the boot stripe, to minimize water lift and back pressure.

Avoid restrictions or long runs on the entire inlet side of the plumbing from the thru-hull to the feed pump module.

Secure the piping away from moving objects such as engine belts and hatches. Prevent chafe on the tubing as required. Test and inspect all piping and hose clamps after several hours of operation.

Pipe Fitting Instructions: To seal plastic-to-plastic fittings, wrap 6 to 8 layers of Teflon tape over their threads. Hold the fitting in your left hand and tightly wrap the threads clockwise. For smoother assembly, do not tape the first (starting) threads.

Wiring

- Pay attention to wire size or system performance will be impaired
- Perform wiring to UL, ABYC, CE or applicable standards

Components

Sea Strainer Mount close to the intake through-hull, in a location that can handle water spillage during service.



Feed Pump Module A

Mount the feed pump module on a vertical surface, no more than 3-feet (1.0M) above the waterline. It is preferable to mount as low as possible. Locate in an area that allows easy access to the charcoal filter, and the service valve. Keep future maintenance in mind when choosing a location, and do not mount above water-sensitive equipment.



NOTE: IF INSTALLING THE Z±ION, SEE Z±ION INSTALLATION INSTRUCTIONS FOR MORE DETAILS.

Feed Pump Module B

5 Micron Prefilter Bowl Locate in an area that allows easy access as this will be the most frequently serviced module while cruising. Mount vertically and leave room below bowl for filter changes.



CAUTION: Do not mount above water-sensitive equipment.

Components - Cont.

Remote Manual Control Box

The remote manual control box should be mounted so the toggle switch can be accessed during trouble shooting or maintenance. It may need to be opened during commissioning in order to optimize the flush duration for the given install. The Remote box has an RJ 45 display jack, two pump power pigtails, a power inlet terminal block, a freshwater solenoid pigtail (blue) and a green pigtail for the option Z-Ion protection system.



Remote Manual Controller

The remote control panel can be mounted anywhere dry and convenient. Cut a 5/8" (1.5 cm) wide by 5/8" (1.5 cm) high opening for the display port. The display needs minimum 2 1/2" deep clearance for the cable. Take care not to damage the plugs on the ends of the cable when routing. The recommended display cable is a standard Cat 5e ethernet cable.



NOTE: Use only a Spectra approved cable.

Clark

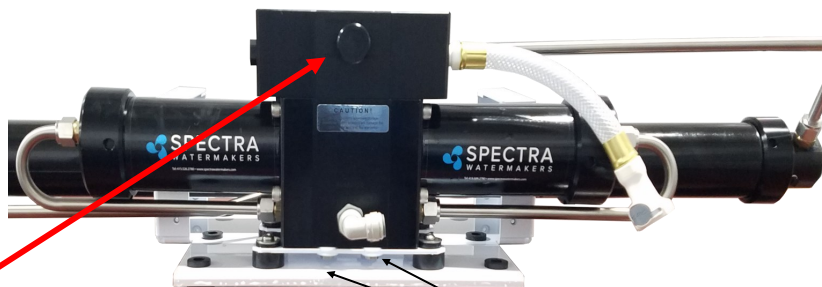

Pressure Relief Valve

Double rubber mounts
to absorb vibration



NOTE: This module **must** be installed in an area that maintains a temperature below 113°F (45°C). It may be placed as high in the boat as you desire, and mounted in any position, even upside down. Make sure that the area around and under the pump does not have any water sensitive equipment, as water will be spilled during any repairs or if a leak occurs. Allow for easy access to the pressure relief valve.

The Clark pump and membrane module comes complete with a mounting system. Be sure to use the supplied washers on the rubber feet.

Cape Horn Xtreme 330R Plumbing Layout

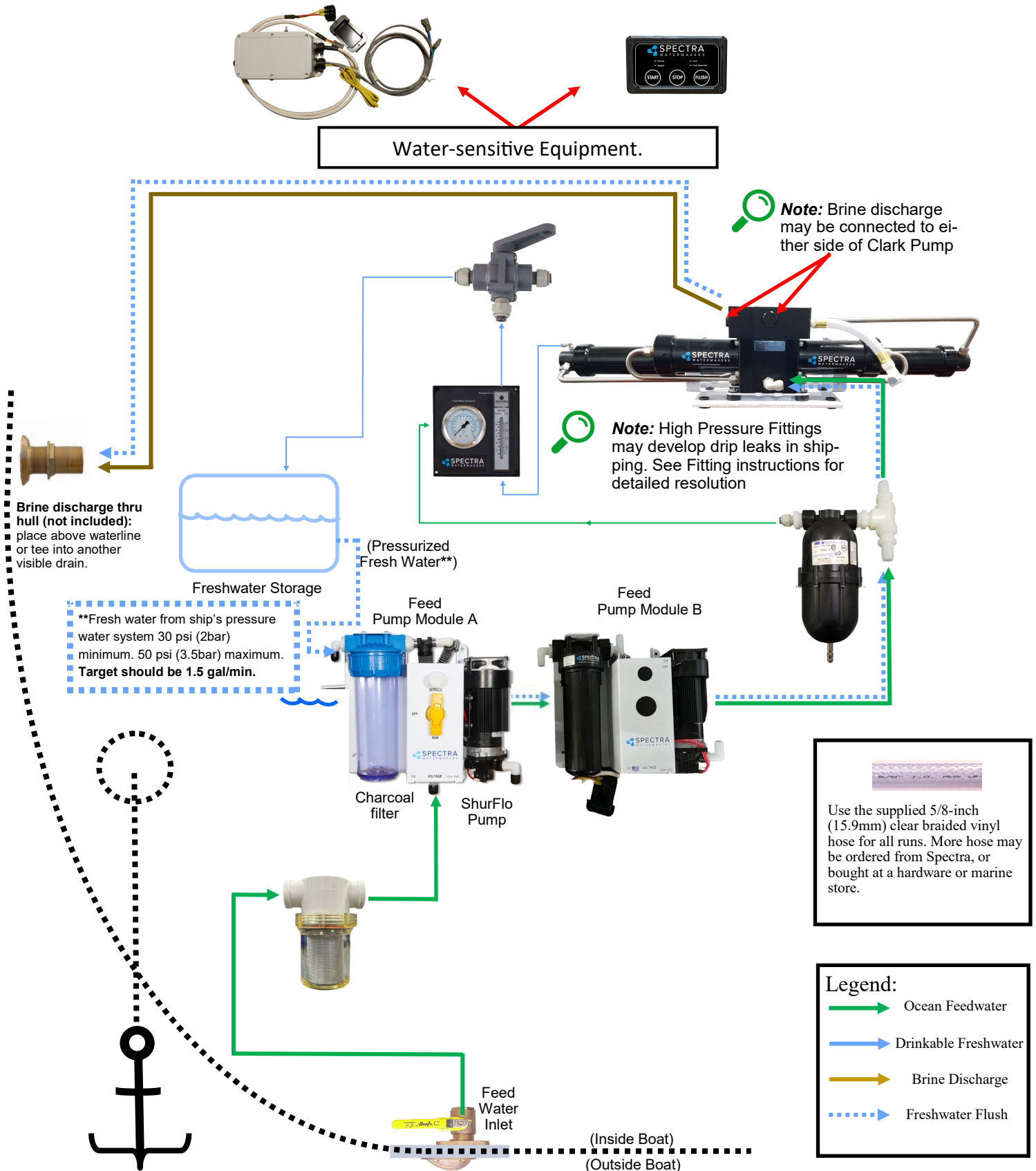

Product Water Plumbing and Pressure Gauge Tube Installation

Sampling Tap for testing the product water.

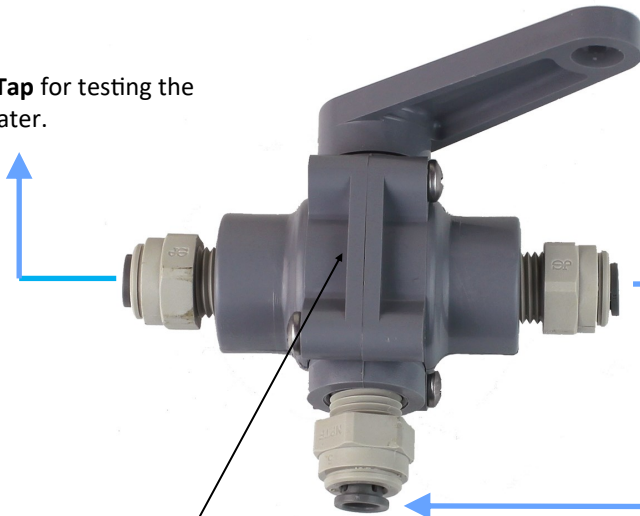

Product to tank: Route the product water from the valve into the top of a vented tank. Install a tee in the water fill or tap a pipe thread into an inspection port.



CAUTION: DO NOT! feed the product into a vent line, manifold, or the bottom of the tank. Make sure that there is no restriction in this piping. **Pressure in the product tubing must never exceed 5psi (.3bar)**, running or stopped, or the membrane will be permanently damaged.

Product Sampling Valve: Mount using the supplied plastic straps.

Note: the handle points in the direction of flow.



Use accumulator port to connect the pressure gauge with the supplied 1/4" black nylon tubing. Tubing must be pressure rated to 150 PSI (10 BAR).

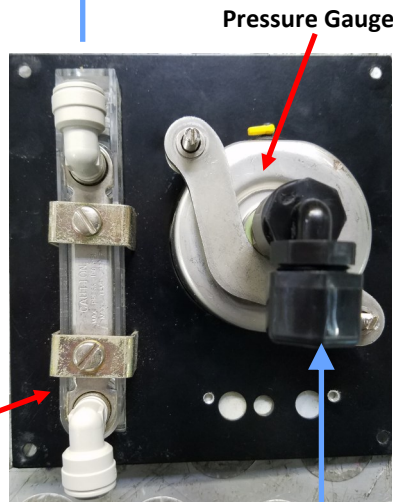

Product Flow Meter

Back view of instrument panel

Use the supplied 1/4" black tubing for the product water plumbing.

Product output fitting.



Cape Horn 330 Remote System Wiring

Cape Horn Extreme 330 Remote Manual systems are pre-fitted with waterproof connectors for electrical and signal cables. Each connector is different, so it is impossible to connect them incorrectly, and the connectors are color-coded. The system has a power inlet harness with a terminal block and cover, two Pump Power cables, 2-conductor fresh water flush solenoid cable, a Z-Ion power and signal cable, and a 25-foot cable for the Remote Manual Controller.



Do not install it in hot or poorly ventilated locations.

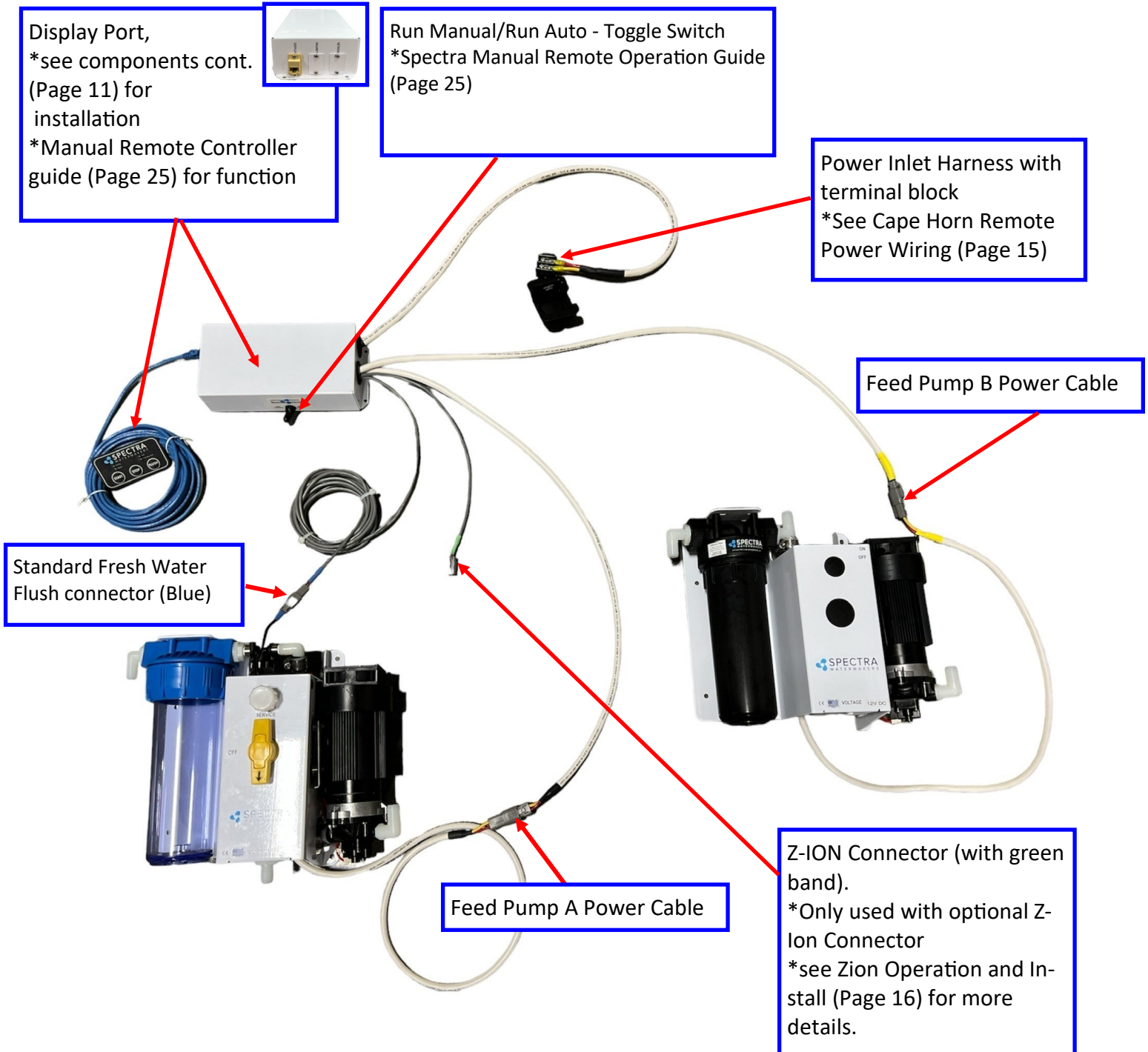

Cape Horn Remote Power Wiring

DANGER:



Installation

- Connect wires using supplied terminal blocks.
- Use marine grade breakers and avoid house breaker panels that could be accidentally tripped.
- Mount the main power terminal block in a junction box or on a bulkhead adjacent to the feed pump module.
- Make sure that this is a dry location well above bilge level and not subject to water spray.
- Be sure to install the terminal block cover
- Confirm the voltage and polarity before wiring to the unit
- Gauge wire so the appropriate voltage is provided to the system. Use a Digital Multimeter to ensure the voltage at the power terminal block is at the nominal specifications for the system.
- DC power feeds should be uninterrupted to ensure proper operation.
- If the specified circuit breaker sizes are unavailable, use the next higher rating but do not exceed the specification by more than 10%.
- **Upon successful power up the remote display will turn on and a freshwater flush may engage.**



Warning

- All wiring and over current protection must be done to applicable ABYC, Marine UL, or CE standards.
- Check for exposed wiring throughout entire installation before supplying voltage to unit.



System performance is voltage specific.



Do not apply voltage to the unit that exceeds 14.6V / 29.2V to 12V / 24V models. Serious damage to the electrical system may occur.



Applying less than 10.4V / 20.8V to 12V / 24V Models will impact functions of control system



Applying less than 12.8V / 25.6V to 12V / 24V Models will increase rate of wear on system motor and pump.

	12 Volt Models	24 Volt Models
Nominal Production Voltage	13.5V DC	27V DC
Nominal Production Amperage	19 Amps	11 Amps
Max Amperage	20 Amps	11 Amps
Recommended Breaker Size	25 Amp	15 Amp

Optional Z-Ion Protection System & Installation

The Z-Ion, developed by Spectra, protects the entire system from fouling for extended periods without fresh water flushing or storage chemicals (pickling).



The Z-Ion achieves this end by introducing a stream of metallic ions into the fresh water flush water, thus flooding the entire system with ions that prevent biological growth for up to thirty days. If you are going to let your system sit idle for longer than thirty days, you will still need to treat it with SC-1 storage chemical or propylene glycol.

The Z-Ion will not prevent freezing, so in freezing climates pickling with propylene glycol is still required. Even with the Z-Ion there may still be cases when you need to pickle your system with SC-1 storage chemical or propylene glycol, so we recommend you carry one of these products at all times.

Installation

For a detailed overview of the Z-ION installation, see below.

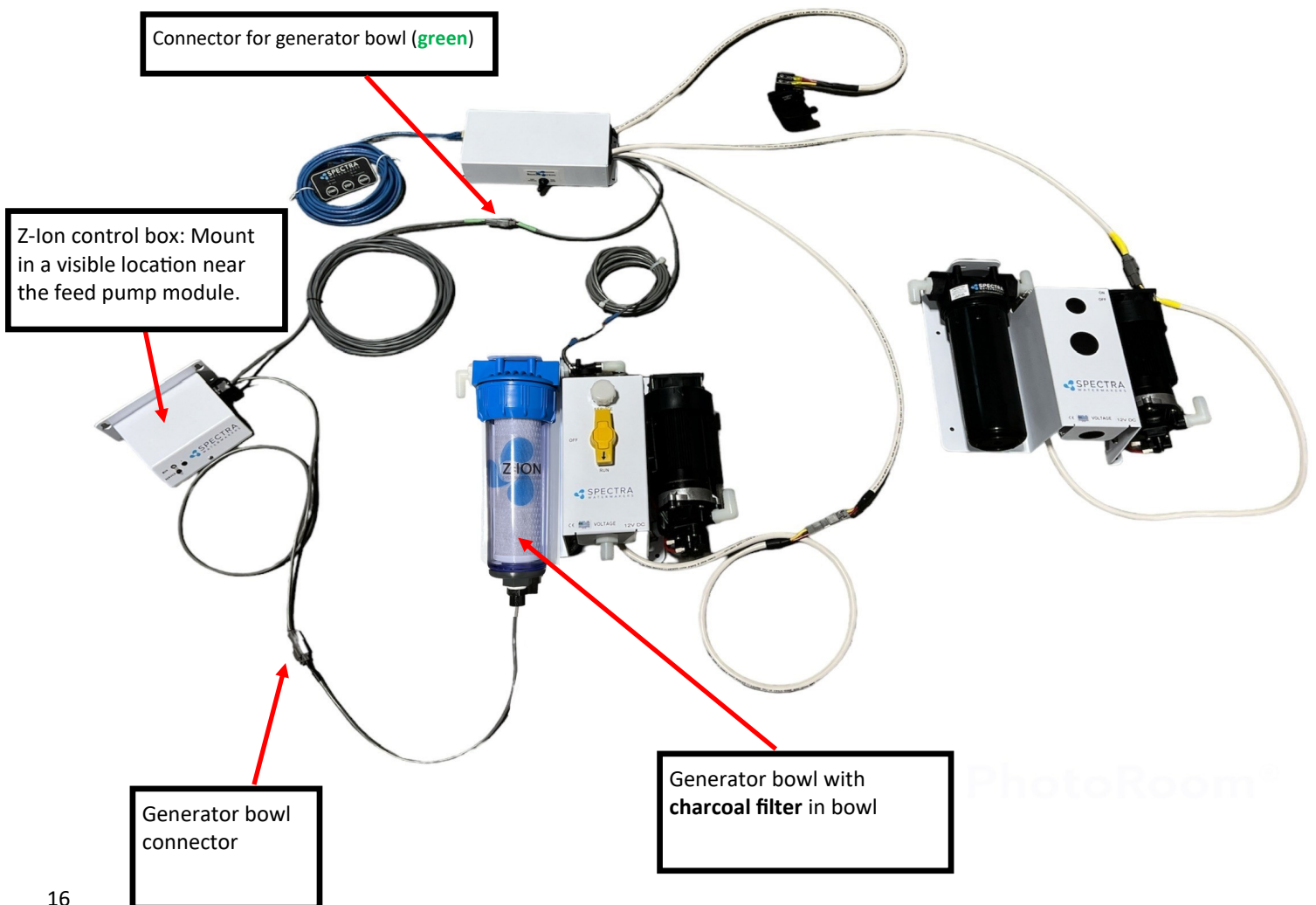

Optional Tank Switch

Customer-Supplied Tank Full Switch

Installing an optional tank full float switch at the top of your water tank allows the watermaker to fill your ship's water tank then automatically stop running. The user can then fresh water flush with by hitting 'Stop' and then 'FWF' on the Remote Controller.

Your watermaker **does not** come with the top-mounted Tank Full Switch (EL-SWT-LV). However, this part can easily be sourced from your local dealer or Full Service Provider if you wish for your system to automatically stop once your freshwater tank is full.

If you do not install the Tank Full switch in your tank, you MUST MANUALLY STOP the system when your freshwater tank has been filled. The system will not stop automatically.



NOTE: The float may need to be flipped 180 degrees to work properly. Many floats can be easily flipped by removing the clip opposite the wire.

Drill and tap a 1/8" NPT port into the top of the fresh water tank that is being filled by the watermaker. This can be installed on a tank access cover, or directly into the water tank. If installing on an access cover, be sure to leave a service loop on the float switch wiring to allow removal of the tank access cover.



Optional Tank Switch - Cont.

The customer supplied float switch must be connected to the **Terminals 5 & 6** labeled **Tank Full** within the Control Box that is mounted to the inside of the Feed Pump Module. There is no polarity. Remove the jumper. Connect the wires to the terminals.

Use 18/2 tinned wire or larger. Wire is not included in the installation kit.

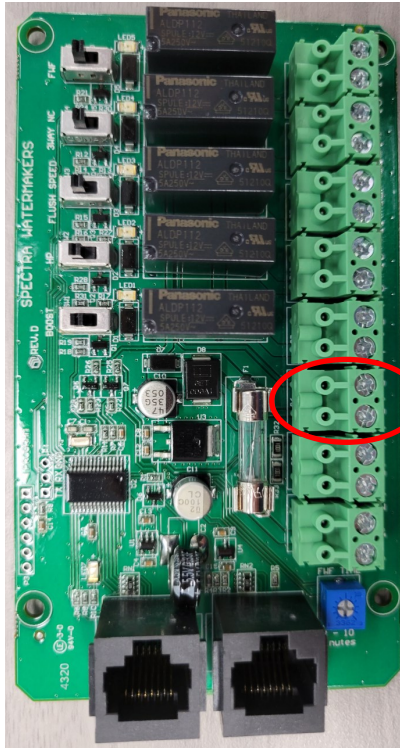

Connect to
Terminals 5 & 6



Note: Remove **only** the jumper in terminals 5 & 6.

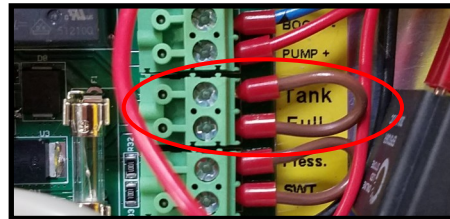

Your watermaker should never be left running unattended.

Watermakers should never be run unattended.



Tank Full

If a tank switch has been installed, the "Running" and "Stopped" lights will be illuminated when the tank is full and the system will stop.

New System Start Up

New System Startup and Testing Freshwater on Dock

Every new system is shipped from the factory with nontoxic, food-grade propylene glycol. Propylene glycol, Spectra Chemicals, or anything other than seawater or freshwater must be purged from the system with the pressure relief valve open at least 1/2 turn. You can purge your system with seawater or freshwater via the Spectra's freshwater flush function. The system must be purged for a minimum of 60 minutes, or until at least 40 gallons (151.42 liters) of water have moved through the system.



CAUTION: Damage will occur if the purge process is not properly followed and the membrane is pressurized with chemicals in it. Check that no hoses are kinked or restricting flow.

Follow this procedure for starting a new system the first time, and after a system has been stored or cleaned with chemicals.

First check that:

- All of your hose connections are tight.
- The green warning tag and washer have been removed from under the pressure relief valve.
- The pressure relief valve is open at least 1/2 turn.
- The sampling valve is set to the sample position.
- The brine line is able to freely discharge

Remove Tag and Washer



Open 1/2 Turn



Sampling Tap to Sample

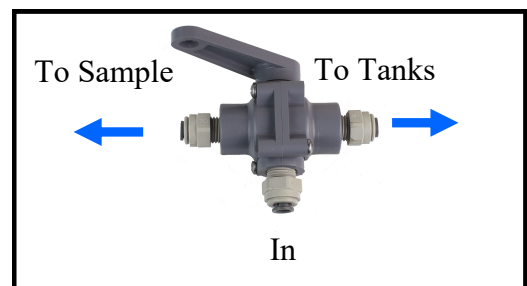

**For purging with seawater see next page.*

For a purge using the freshwater flush:

- 1) Ensure The vessel's pressurized water system is on
- 2) Locate the potentiometer screw on the circuit board (pictured on pg. 34) and turn this all the way clockwise to increase the flush duration to 10 minutes.
- 3) Flush 6 times in succession will achieve a 60 minute purge.
- 4) Remember to turn the flush potentiometer screw back close to its original position after this is complete. Only proceed to **step 5 on purging with seawater:** (Close the pressure relief valve. Turn on Pump B. The pressure should rise to 90-100 PSI. If pressure does not rise Feed Pump A may need to be turned on and off in order to prime both pumps. Water should begin to flow out of the sampling tube. If the ship is located in brackish or fresh water the pressure will be lower) for the product purge once you can run the system in seawater. In the interim, ensure the system is flushed with freshwater weekly or preserved with bio-cide.

New System Startup and Testing in Ocean

Every new system is shipped from the factory with nontoxic, food-grade propylene glycol. Propylene glycol, Spectra Chemicals, or anything other than seawater or freshwater must be purged from the system with the pressure relief valve open at least 1/2 turn. You can purge your system with seawater or freshwater via the Spectra's freshwater flush function. The system must be purged for a minimum of 60 minutes, or until at least 40 gallons (151.42 liters) of water have moved through the system.



CAUTION: Damage will occur if the purge process is not properly followed and the membrane is pressurized with chemicals in it. Check that no hoses are kinked or restricting flow.

Follow this procedure for starting a new system the first time, and after a system has been stored or cleaned with chemicals.

First check that:

- All of your hose connections are tight.
 - The green warning tag and washer have been removed from under the pressure relief valve.
 - The pressure relief valve is open at least 1/2 turn.
 - The sampling valve is set to the sample position.
- The brine line is able to freely discharge

Remove Tag and Washer



Open 1/2 Turn



Sampling Tap to Sample

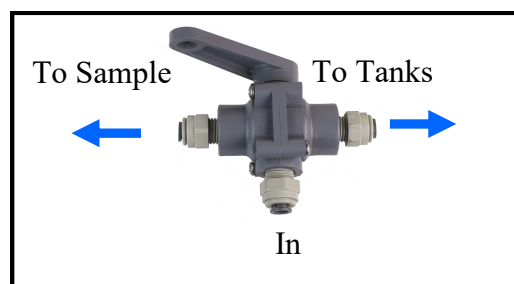

For a purge with seawater :

- 1) Move to an area free of contaminated water, such as in a polluted harbor or canal.
- 2) Make sure the inlet thru hull/seacock is open.
- 3) Turn on Feed Pump A and check to make sure water is coming out of the brine discharge (thru-hull above water).
- 4) Run the system without pressure for 60 minutes to purge the storage chemicals. The pressure gauge should read less than 3 5 PSI. If purging with freshwater the sampling tube may discharge water.
- 5) Close the pressure relief valve. Turn on Pump B. The pressure should rise to 90-100 PSI. If pressure does not rise Feed Pump A may need to be turned on and off in order to prime both pumps. Water should begin to flow out of the sampling tube. If the ship is located in brackish or fresh water the pressure will be lower.
- 6) Depending on storage and environmental conditions the system may need to have additional purging time. If the product water does not taste pure or sample below 500 ppm, purge or run the system for up to 6 additional hours.
- 7) The system may be run with only one feed pump at a time or with both pumps simultaneously. Water quality may improve slightly when running with both pumps, as product salinity decreases with higher feed pressure.

Operation

Normal Operation and Fresh Water Flush

If the system has been pickled, stored, or contains cleaning compounds, use the New System Startup procedure. The system should be fully run tested before you leave port. If the location or weather prevents proper testing refer to "Testing with an Artificial Ocean."

THE VENTURA 200T IS DESIGNED FOR WARM WATER USE. OPERATION IN WATER BELOW 50 DEG F (10 DEG C) MAY CAUSE HIGH OPERATING PRESSURES AND INCREASED WEAR

1. Check that the thru-hull inlet is open.
2. Turn the product sample valve to the **SAMPLE** position.
3. Turn the yellow service valve handle on the feed pump module to **RUN**.
4. Start the system by pushing 'Start' and check for flow by inspecting the brine discharge and checking for pressure on your analogue gauge. If there is no flow, open the pressure relief valve on the Clark Pump to prime the system and bleed the air out of the feed pump.
5. After 5 minutes, check the product water with your handheld salinity tester. When it is below 750 PPM, divert the product into your tank by rotating the product sample valve handle 90 degrees.
6. Run the system until you have filled your tank or have made enough to meet your requirements.
7. Following your water making session, perform a freshwater flush.

Freshwater Flush (You should freshwater flush your watermaker after EVERY use.)

1. Push the **Freshwater Flush** button on the remote panel.
2. The freshwater flush solenoid will open and feed pump will come on, allowing pressurized freshwater to flow through the system. Pressure will drop on the gauge, which indicates that the membrane is flooded with fresh water.
3. After a proper flush, the ppm of the brine discharge should be below 1000ppm.

You may now leave the system unattended for up to five days (30 with the Z-Ion) without further attention.

Remember that you need to run the system almost a half an hour to make enough water for a flush. You may notice that the system output is higher while charging your batteries, as the machine is voltage sensitive.

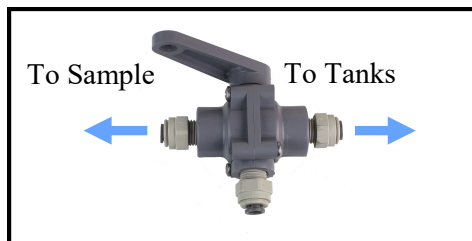

3-Way Product Sampling Valve



Analogue Gauge Panel



Remote Panel

Nominal Parameters

	AMPS				Feed Pressure	Static * Pressure	Feed Flow				Product Flow				Watts/Gallon		
	12V	MAX	24V	MAX			Flow	MIN	MIN	Flow	Flow	MIN	MIN	Nom	Max		
Both Pumps	≈ 19	20	≈ 10	11	PSI	bar	PSI	GPM	LPM	GPM	LPM	GPH	LPH	GPH	LPH	16	18.4

For Spec Production:

12V Systems: Run at 13.2 VDC min

24V Systems Run at 26.4 VDC min

Dry Testing with an Artificial Ocean

If it is not possible to test run the system with the boat in the water, you may test the system with an artificial ocean. You will need 1.3 lbs. of non-iodized salt (rock salt, sea salt, or aquarium salt) to make a 5 gallons (33 grams of salt per liter) of water that is about 33,000 PPM salinity (average seawater salinity). Make sure the domestic water system is powered up and the boat's tank has at least 60 gallons (230 Liters) of water to purge the storage chemicals from the system. Confirm that the charcoal filter is installed in the feed pump module, and the domestic water line is connected. If freshwater system is not available & system is still pickled, alter beginning procedure to feed unchlorinated water through the service port to purge out storage chemical.



1. **Open the pressure relief valve on the Clark Pump. Remove the green tag and spacer, if still attached.**
2. Press the **Freshwater Flush** button to run a full flush cycle. If there are storage chemicals in the system, flush for additional time to purge out chemicals. SC-1 minimum 20 minutes purge, Propylene Glycol minimum 60 minutes purge.
3. Connect the **black spiraled intake service hose**** to the service port on feed pump module, then connect the **vinyl brine discharge service hose*** to the quick disconnect fitting on Clark Pump. Refer to the photos below. Route both hoses into the 5 gallon (20 Liter) container. Turn the product sample valve to the sample position, and route the **product** into the bucket.
4. Using the remote panel, select **Freshwater Flush**. Run until the bucket is filled.
5. Turn the yellow valve to **SERVICE**.
6. Mix salt with the freshwater to the proper proportion or use an aquarium hydrometer to adjust the salinity level.
7. Push the **Start** button to run the system.
8. Allow the system to prime and then close the pressure relief valve. The system should build pressure shortly and start making water, with the brine and product water recombining in the bucket to be cycled again. This will gradually heat the water. Do not let the water temperature exceed 120 deg. F (49 deg. C).
9. Run the system under pressure, checking for proper operation and leaks. After testing the system, re-install the brine discharge hose, product tube, and freshwater hose from the strainer. You can now flush the system by pressing the **Freshwater Flush** button.



Service valve OFF, in FLUSH position



*Connecting brine discharge service hose at quick disconnect



Remote panel



**Intake service hose connected and yellow service valve handle to SERVICE



**Black spiraled reinforced intake service hose



*Vinyl Brine Discharge Service Hose

Spectra Manual Remote Controller Guide

If the system has been pickled, winterized, this is the first startup, or the condition of the system is unknown, go to NEW SYSTEM START-UP on page 19 or serious damage may occur.

A fresh water flush should be performed after every use of the watermaker. The system will need to run for approximately 15 minutes to make enough fresh water for one flush.



Start

Pressing the 'Start' button begins watermaker operation.



Stop

Pressing the "Stop" button ends watermaker operation. The "Stop" button must be pressed before beginning a Fresh Water Flush.



Fresh Water Flush (FWF)

Pressing the 'Fresh Water Flush' button floods the watermaker with fresh water from the vessel's domestic water tanks. Opens solenoid valve to allow water to flow from tank instead of seawater from the thru-hull. Fresh Water Flush mode will end automatically after flush is complete, approximately 3 minutes.



Run Manual Operation

The remote manual circuit board, its functions and protections, can be bypassed all together by engaging the toggle switch to "Run Manual". When the switch is engaged both motors will receive power and will only cease to run when the switch is turned back the to Auto Position, tank float switch will not disengage the system.

Running the system without a display is possible, however, it is not recommended unless alternate measures are taken to freshwater flush the system after every use. Such as running dechlorinated (or product) water through the system via the service port.

Adjusting Fresh Water Flush Duration

The Cape Horn Freshwater Flush Duration is set to a factory default of **3 minutes**, which is usually the right amount of time to ensure that sea water is thoroughly flushed out of the watermaker using the least amount of fresh water. However, due to different lengths of hose runs, different rates of flow, and different pressures in shipboard fresh water systems, the flush duration can be optimized for your boat.

Set the Flush Duration with a small screwdriver so that the fresh water flush comes to an end just as the salinity of the brine discharge drops below 1000 PPM, or no longer tastes brackish. Since the flush duration can only be adjusted in round minutes, you may want to lessen the duration to 2 minutes, to save water, or increase to 4 or more minutes to ensure a thorough flush.

Also, the charcoal filter is rated for 1.5 GPM (6 LPM): If the system pushes more than 1.5 GPM through the charcoal filter (4.5 gallons in 3 minutes), a flow regulator can be added.

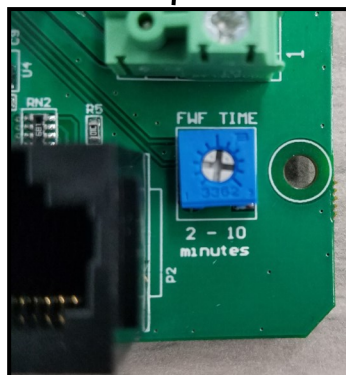
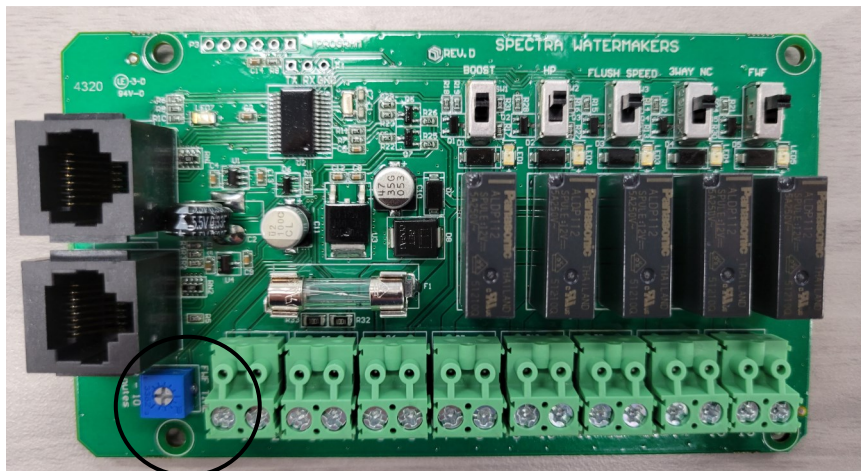

Suggested Spares

Short term cruising, weekends, etc.:

We suggest two treatments worth of preservative chemicals (either 2 bags of SC-1 or 2 gallons (8 liters) of Propylene Glycol). Six 5-micron filters and one Carbon filter.

Cruising 2 to 6 months at a time:

Twelve 5-micron filters, 2 Carbon filters, enough preservative chemicals for 4 treatments, one replacement feed pump head.



CAUTION: Longer than 6 months:

Additional filters, Offshore Cruising Kit consisting of Clark Pump seals, O-rings, tools, and membrane cleaning chemicals. One replacement strainer screen, O-ring for strainer screen, O-rings for filter housings. Additional feed pump heads and/or feed pump diaphragms.

Common Parts

SC-1 STORAGE CHEMICAL
SC-2 CLEANER
SC-3 CLEANER
BASIC CRUISE A
OFFSHORE REBUILD KIT
5 MICRON FILTER
CHARCOAL FILTER
5" STRAINER SCREEN
OIL/WATER FILTER
FEED PUMP
FEED PUMP HEAD
FEED PUMP DIAPHRAGM
5" STRAINER O-RING
FILTER HOUSING O-RING
CHARCOAL FILTER HOUSING O-RING

Part Number

KIT-CHEM-SC1
KIT-CHEM-SC2
KIT-CHEM-SC3
KIT-BCK-A
KIT-OFFSH
FT-FTC-5
FT-FTC-CC
FT-STN-5S
FT-FTC-OW
EL-FP-12V or 24V
PL-PMP-SFPH
EL-FP-DP
SO-STN-5SS
SO-FHS-10H
SO-FHS-3PCS10

All sales are made through Spectra's network of dealers/full service providers. Contact your local full service provider for additional suggestions and support.

Maintenance, Storage, and Troubleshooting

Maintenance

General

Periodically inspect the entire system for leakage and chafing. Repair any leaks as soon as you find them. Some crystal formation around the Clark Pump blocks is normal. Wipe down any salt encrusted areas with a damp cloth.

Watermakers are at their best when run regularly. Biological fouling in the membrane is more likely when a watermaker sits idle. A warm environment will cause more growth than a cold environment. A fresh water flush every five days will greatly reduce biological growth but may not stop it completely. You can also protect your watermaker with the optional Z-Brane or Z-Ion systems: Both protect the membrane from bio-fouling without the use of storage chemicals.



DANGER/ATTENTION: For maintenance, always disconnect from power source first.

The Seawater Strainer

The seawater strainer's stainless steel element should be inspected, removed, and cleaned as needed.



ATTENTION: Ensure that the thru-hull is closed before disassembly and the gasket is in place before reassembly. When the system is put into storage, remove the strainer, rinse with fresh water, and reassemble dry to impede corrosion. Check frequently during operation.

The Prefilter

Service the prefilter on a regular basis. If the system is installed as shown on the plumbing schematic, the pressure will fall on the remote gauge as the prefilter becomes dirty. Extremely dirty filters will harm system performance and may cause the feed pump to cut out from high pressure. Leaving dirty filters in the machine during long idle periods will cause biological contamination. **Please review prefilter bulletin to page 48. prior to running your system.**



NOTE: Prefilter elements must be changed frequently. The rate is solely dependent on the input water. A 5-micron filter might last you a 4-6 weeks in clear open ocean seawater, or be ruined in minutes in a dirty harbor. Spectra does not advise to attempt to clean dirty prefilters. Prefilters are a consumable item and should be changed for new when in question.

To service the filter close the thru-hull, open the prefilter housing, remove the old filter, clean out the housing bowl, and reassemble the housing with a new 5 micron filter element. Leave dry until next startup.



NOTE: Use only Spectra-approved filters or you may void your warranty. Occasionally, lightly lubricate the O-rings with silicone grease.

Maintenance - Cont.

Oil Water Separator (Optional)

For oil/water separation, install the additional filter housing with its oil removal filter *upstream* of the 5 micron filter. Service at the same time as the 5 micron filter.

The Charcoal Fresh Water Flush Filter

Replace the charcoal filter element at least every 6 months. This filter protects the membrane by removing chlorine from the flush water. Use only a Spectra-approved replacement.

The Feed Pumps and Clark Pump

The feed pumps and the Clark Pump require no routine maintenance except inspection for leaks. Tighten any hose clamps or fittings that show signs of leakage. The high pressure fittings threaded into the Clark Pump have O-ring seals with a straight thread. These should never leak and should never be over-tightened. If one of the tube nuts starts to leak, it can be un-threaded, sealed with a bit of silicone grease or oil, and tightened with two wrenches very tightly.

The Membrane

Always perform a flow test before cleaning your membrane. Cleaning with chemicals shortens the lifespan of membranes, so only clean if you are certain it is warranted. The leading cause of fouling is biological growth that forms when the system is left unused without flushing or pickling. Fouling from mineral scaling can happen during operation under certain seawater conditions, and from rust. Monitor the product salinity and feed pressure for higher than normal readings, and take environmental conditions into consideration:

- Cold feed water or clogged filters can cause high pressure.
- Low product flow is usually due to low voltage, a worn feed pump, or a worn Clark Pump.

Test to see if biological growth has occurred: Before running the system, remove the prefilter and examine its condition. If the filter housing is full of smelly, discolored water, the system was not properly stored. Install a clean prefilter.

Next, check the membrane. Attach the brine discharge service hose and lead it into a bucket. Open the pressure relief valve half a turn, and manually run the system for 30 seconds (metal toggle switch on feed pump module). Examine the brine water: If it is discolored and smells bad, perform an SC-2 cleaning with unchlorinated water before running the system pressurized. If the brine is fairly clean, follow the New System Startup procedure and run normally. Check for performance. Clean the membranes **only if** performance is reduced.



NOTE: See the **Cleaning Procedure (pg. 39)** for complete instructions.

Cape Horn Extreme 330R Plumbing Diagram

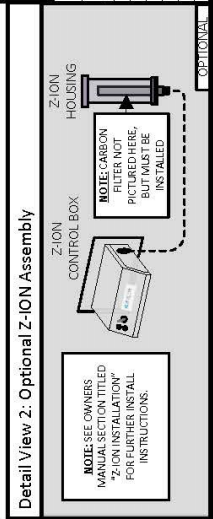
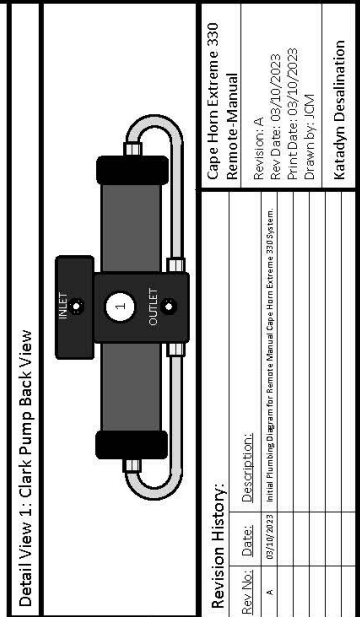
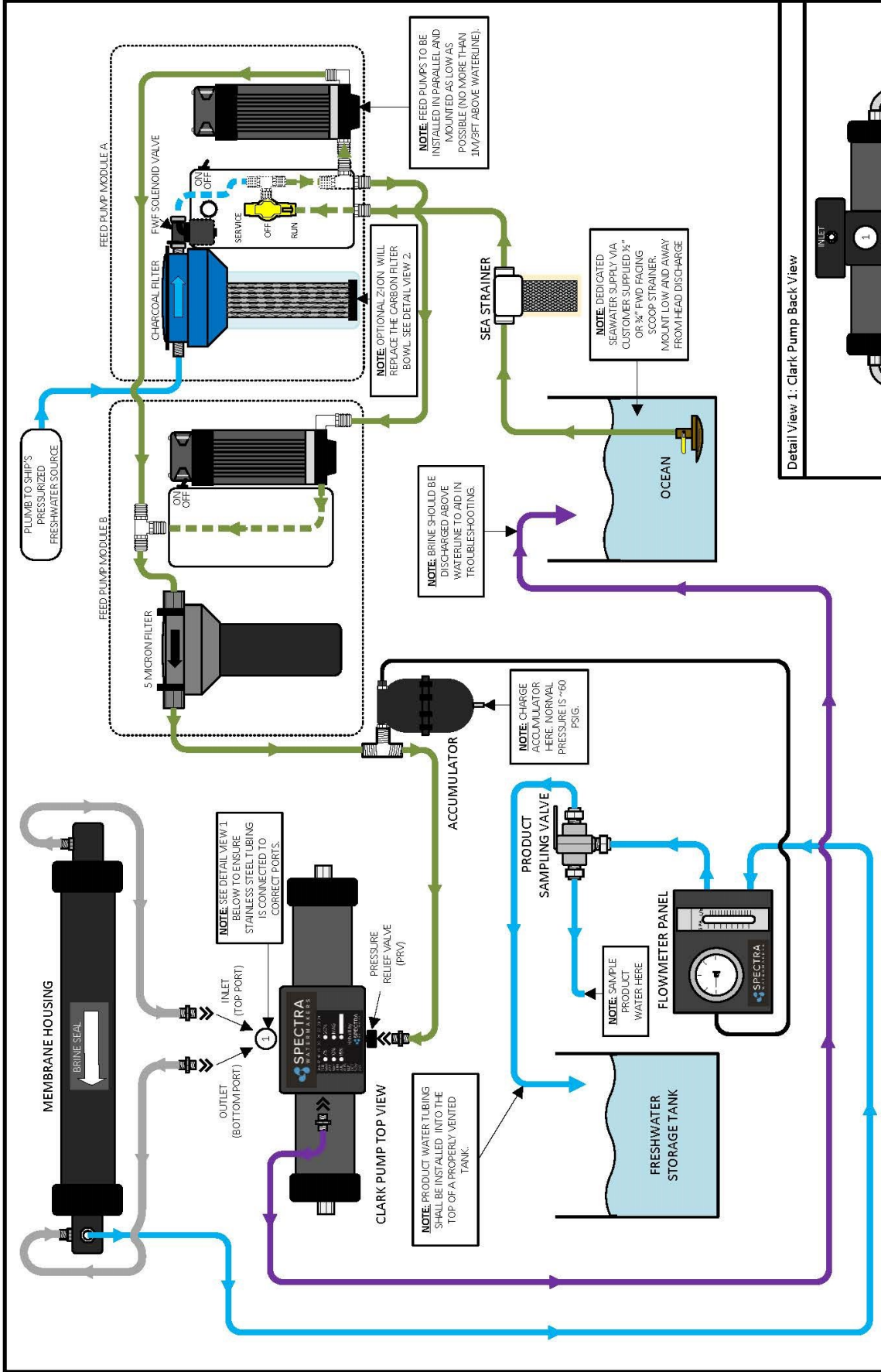





KEY: LIST OF SYMBOLS

SYMBOL	USE	DESCRIPTION
	PRESSURE GAUGE TUBING	BLACK 1/4" VINYL
	LOW PRESSURE INLET HOSES	5/8" CLEAR BRAIDED VINYL
	LOW PRESSURE BRINE DISCHARGE HOSE	5/8" CLEAR BRAIDED VINYL
	PRODUCT WATER TUBING	BLACK 1/4" VINYL
	HIGH PRESSURE TUBING	STAINLESS STEEL TUBING





**Cape Horn Extreme 330R
Electrical Diagram
12V/24V**

Cape Horn Extreme 330R Electrical Specifications





CAPE HORN EXTREME REMOTE 12V W/SHORT

-  **Power Supply Voltage: 12 VDC**
-  **Bench Test: 13.7 V / 20 A**
-  **Power Consumption: 275 W**
-  **Efficiency: 18 Wh/gal**

CAPE HORN EXTREME REMOTE 12V W/LONG

-  **Power Supply Voltage: 12 VDC**
-  **Bench Test: 13.6 V / 21.4 A**
-  **Power Consumption: 292 W**
-  **Efficiency: 19 Wh/gal**

CAPE HORN EXTREME REMOTE 24V W/LONG

-  **Power Supply Voltage: 24 VDC**
-  **Bench Test: 27.2 V / 10 A**
-  **Power Consumption: 273 W**
-  **Efficiency: 18 Wh/gal**

Introduction to Spectra Chemicals

We use four types of chemicals: SC-1, SC-2, SC-3, and propylene glycol antifreeze. SC-1 and propylene glycol are for system storage, while SC-2 and SC-3 are for membrane cleaning.



CAUTION: Do not use metasodium-bisulfate, citric acid, or any other storage chemical not supplied by Spectra. These chemicals, used to store other watermaker brands, are very acidic and will damage the Clark Pump and void the warranty.



CAUTION: Never use any chemicals with the system pressurized! Always open the pressure relief valve 1/2 turn. Always follow the instructions for purging the chemicals as shown in the New System Startup section.

Storage

SC-1 prevents biological growth when your system is idle. It should not be used as a cleaning chemical, nor will it protect your system from freezing. A bag of SC-1 is mixed with 1 to 3 gallons of product or dechlorinated fresh water in a bucket and circulated through the system for 10 minutes. This treatment will protect the system for six months, after which the SC-1 treatment must be repeated. To use SC-1, follow the instructions for **Storage Procedure**.

Spectra systems should be stored with propylene glycol if freezing is likely to occur. Propylene glycol can be used instead of Spectra SC-1 storage chemical for storage in any climate, and treatment is effective for one year. Propylene glycol is a food-grade antifreeze used to winterize RV's, boats, and cabins. Do not use ethylene glycol automotive antifreeze, which is toxic and will damage the system.

The propylene glycol formulations sold in marine and RV stores are usually diluted with water. The water remaining in the watermaker before the storage procedure will further dilute the antifreeze, reducing the microbial protection and increasing the temperature at which the mixture will freeze.

Antifreeze labeled "Minus Fifty" is a 25% solution and will begin to form an icy slush at about 15°F (-10°C) and will only provide burst protection to about 0°F (-18°C). After a further 50% percent dilution by water remaining in the watermaker, "Minus Fifty" antifreeze will only protect from bursting down to about 25°F (-4°C). Therefore if low temperature freezing protection is required a 60% or stronger antifreeze should be used. 60% solutions are labeled "Minus 100" and will provide burst protection to -15°F (-27°C) even after a fifty percent dilution with residual water. "Minus 200" formulations are pure propylene glycol.

Introduction to Spectra Chemicals - Cont.

Complete microbial preservative protection requires a 25% solution of propylene glycol, so care must be taken that the solution remaining in the watermaker during long term storage is at least 25%, even if freeze protection is not required. **For these reasons Spectra recommends that all pickling be carried out with a 60% or greater concentration.**



NOTE: See **Winterizing with Propylene Glycol** on page 39.

Propylene glycol can be difficult to flush from a membrane, especially after extended storage periods. This results in high salinity water (high PPM) and residual flavor in the product water. We recommend flushing the system WITH THE PRESSURE RELIEF VALVE OPEN for 4-6 hours after storage with propylene glycol—the longer the better. If, after extended flushing, you still experience low product water quality, cleaning with SC-2 usually removes all traces of propylene glycol and returns the salinity to the level it was before storage with propylene glycol.

Cleaners

Cleaning can be detrimental to the membrane and shorten its life. Avoid unnecessary cleaning, and avoid cleaning as a diagnostic tool.

SC-2 is an alkaline cleaner used to remove light oil, grime, and biological growth. It is most effective if heated to 120°F (49°C), which is difficult on a boat. In most cases the water quality will increase in PPM (salinity) after an SC-2 cleaning. After a few hours it should recover to near the level it produced before the cleaning.

SC-3 is an acid cleaner used to remove mineral and scale deposits. In most cases this is used first and if there is no improvement, go on to the SC-2. SC-3 will in most cases lower the product PPM and overall pressures. Scaling is a slow process that may take several months or years. SC-3 is less harmful to the membrane and will almost always improve the performance of an older membrane.

For cleaning with either SC-2 or SC-3, see the **Membrane Cleaning Procedure** on page 40.

Cape Horn Remote Manual Storage Procedure



NOTE: The Cape Horn contains about 2 gallons of water at any given time, so with 2 gallons in the bucket there will be a total of 4 gallons of solution.

1. Close the saltwater intake seacock.
2. Push the **Freshwater Flush** button to perform a flush. **Repeat** a second flush.
3. Disconnect the brine discharge hose from the Clark Pump at quick disconnect. Replace with the **vinyl brine service hose*** from your service kit. Lead the service hose into a 5 gallon bucket.
4. Push **Freshwater Flush** again and stop the feed pump when the bucket has filled with one gallon of non-chlorinated freshwater (or fill a bucket with a gallon of distilled).
5. Mix one 8 oz. container of SC-1 storage compound with the water in the bucket. It will not dissolve completely, which is normal, and any undissolved particles will be caught by the prefilter.
6. Connect **black spiraled reinforced service hose**** to the service port (garden hose style fitting) above the yellow valve on the feed pump module and lead the hose into the solution in the bucket, creating a closed loop. Turn the yellow service valve to **SERVICE**.
7. **CAUTION: Ensure the pressure relief valve on the Clark pump is OPEN (unpressurized), 1/2 turn counterclockwise OR THE MEMBRANE WILL BE DAMAGED.**
8. Turn on the feed pump using **manual toggle switch*****. The system will draw solution from the bucket and return it via the brine discharge hose. Circulate the storage solution through the system for 20 minutes. Turn off the feed pump when finished.



Clean Up:

1. Remove the brine service hose from the Clark Pump brine discharge using quick disconnect, and replace with the original hose that leads to the discharge thru-hull.
2. Pump the bucket dry using the **manual toggle switch**, turn off when empty.
3. Turn the yellow service valve back to RUN. Remove the intake service hose, and replace the cap.
4. Close the seacock, drain then clean the sea strainer and prefilters. Reassemble dry with new filters. Leave the pressure relief valve open, since the next time you run the system you will need to purge the storage chemicals with the system unpressurized.

Your system is now protected from biological growth for 6 months.



Service valve OFF, in FLUSH position

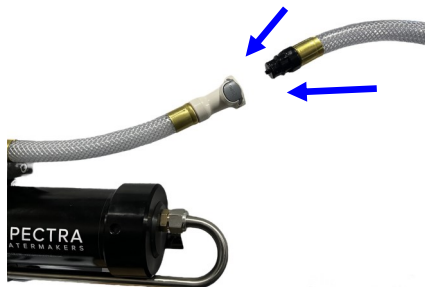

*Connecting brine discharge service hose at quick disconnect



***Manual toggle switch



**Intake service hose connected and yellow service valve handle to SERVICE



**Black spiraled reinforced intake service hose



*Vinyl Brine Discharge Service Hose

Winterizing with Propylene Glycol

See description of propylene glycol formulations, and flushing from system on page 36.

1. Close the saltwater intake seacock.
2. Push the **Freshwater Flush** button to perform a flush. **Repeat** a second flush.
3. Disconnect the brine discharge hose from the Clark Pump at quick disconnect. Replace with the **vinyl brine discharge service hose*** from your service kit. Lead hose into a 5 gallon bucket.
4. Push **Freshwater Flush** and stop with one gallon of freshwater in the bucket (or use distilled).
5. There are two gallons of water in the watermaker, so add potable water antifreeze to the bucket per the label instructions based on the protection level needed.
6. Connect **black spiraled intake reinforced service hose**** to the service port (garden hose style fitting) above the yellow valve on the feed pump module and lead the hose into the solution in the bucket, creating a closed loop. Turn the yellow service valve handle to **SERVICE**.
7. **CAUTION: Ensure the pressure relief valve on the Clark Pump is OPEN 1/2 turn (unpressurized).**
8. If a stronger concentration of antifreeze is required you can discard the first one or two gallons of water from the discharge line before placing it into the bucket to recirculate. Add more propylene glycol to the intake bucket if necessary. Turn on the feed pump using the **manual toggle switch***** and the pump will draw propylene glycol from the bucket, and the brine discharge service hose will return it, creating a closed loop. Run the feed pump and circulate the antifreeze for approximately 20 minutes. Stop the feed pump by moving the toggle switch back to 'RUN AUTO'.



Clean Up:

1. Remove the brine discharge service hose from the Clark Pump, and replace with the original brine discharge hose that leads to the thru-hull. You may now pump the bucket dry by engaging the toggle switch again. Stop when the bucket is empty, switching back to 'RUN AUTO'.
2. Turn the yellow service valve handle to **OFF**. Disconnect the intake service hose and replace cap.
3. Drain the seawater strainer and the hose leading to the feed pump module. Disconnect the product tubing from the membrane housing and blow residual water out of the tubing. Empty the charcoal filter housing and flush water lines.

Your system is now protected from biological growth and freezing for 12 months.



Service valve OFF, in FLUSH position

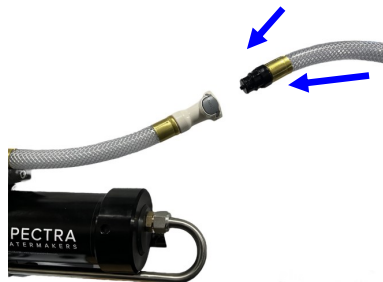

*Connecting brine discharge service hose at quick disconnect



***Manual toggle switch



**Intake service hose connected and yellow service valve handle to SERVICE



**Black spiraled reinforced intake service hose



*Vinyl Brine Discharge Service Hose

Membrane Cleaning Procedures

Spectra cleaning compound (SC-2 or SC-3) must be mixed with freshwater at a ratio of 1 container of compound to 3 gallons (12L) of non-chlorinated water. An average of two gallons (8L) of water is already present inside a Cape Horn 330 Extreme Remote Manual system, so this water must be figured into the mixture. A Cape Horn 330R system requires one container of compound per cleaning.

1. Turn the yellow service valve on the feed pump module to **OFF** (horizontal, see photo*).
2. Push **Freshwater Flush** to flush the system. **Repeat**, to flush the system twice.
3. Remove the cap on the service port on the feed pump module and install the **black spiraled reinforced intake service hose**** from the service kit. Remove the quick disconnect fitting from the brine discharge outlet of the Clark Pump, and replace it with the **vinyl brine discharge service hose*****. Lead both hoses into a 5 gallon (20 liter) bucket.
4. Push the **Freshwater Flush** button and run the feed pump until one gallon of fresh water runs into the bucket from the brine discharge service hose (or fill with a gallon of distilled water). Stop the system.
5. Turn the yellow service valve to the **SERVICE** position.
6. **CAUTION: Make sure that the pressure relief valve on the Clark Pump is open (unpressurized).**
7. Mix the SC-2 or SC-3 cleaning chemical in the bucket with the freshwater. If possible (for maximum effectiveness), heat the solution to approximately 120°F(49°C).
8. Start the system using the **manual toggle switch****** on the control box. The intake service hose will draw solution from the bucket and the brine discharge service hose will return it. Circulate the solution through the system in this manner for 45 minutes.
9. Stop the pump. Replace the brine discharge overboard hose and run the pump until the bucket is empty. Stop the pump and turn the yellow service valve back to the RUN position. Restart the pump and run for 20 minutes to flush the chemicals out of the system (**DO NOT CLOSE the pressure relief valve!**)
10. Move the manual toggle switch on the Control Box to RUN AUTO.

The system may now be restarted, flushed, or stored.



*Service valve OFF, in FLUSH position



***Connecting brine discharge service hose at quick disconnect



****Manual toggle switch



**Intake service hose connected and yellow service valve handle to SERVICE



**Black spiraled reinforced intake service hose



***Vinyl Brine Discharge Service Hose

Flow Test for Dual ShurFlo Pumps (Cape Horn Extreme 330R)



NOTE: The flow test is the most useful diagnostic test for system performance, and should be done before replacing or cleaning your membrane. Changes in production or water quality are normally caused by something **other than** the membrane, unless the system has been left unused for a long time.

Before the flow test, change the prefilter and clean the sea strainer. Carefully check for water or air leaks, as air in the system will cause low production and erratic salinity. Look for air bubbles in the product flow meter, feed water hoses, and brine overboard hose.

Run the system and watch the pressures very closely. If the feed pressure to the Clark Pump is asymmetrical from one stroke to another, this could be part of the problem. **A difference of a few PSI is acceptable, but anything over that is an issue.** If the pump is asymmetrical, Clark Pump repairs should be done before continuing with these tests.

If no asymmetry is noted, continue with this test.

You will need a graduated bucket, either a graduated pitcher or large measuring cup (or any container of a known volume), and a stopwatch. Before the flow test, change all filters and clean the sea strainer. Carefully check for water or air leaks, as air in the system will cause low production and erratic salinity. Observe the feed pressure and ensure that the Clark Pump cycles symmetrically. Log the voltage at the feed pumps at the same time. Confirm at least 12.5 Volts at the feed pump on 12-Volt DC systems; 25 volts on 24-Volt DC systems.

Take two measurements and compare them with the table in the New System Startup section. The first measurement is the product flow alone. The second is the product flow combined with the brine discharge flow to get the total flow or feed flow. You may take these measurements by two methods:

1. Time the product flow into a graduated pitcher, then divert both the product flow and brine discharge together into a bucket to measure total flow.

OR

2. Divert the product flow into the pitcher while diverting the brine discharge into the bucket. Time the flow of both. After calculating the product flow, pour the pitcher of product into the bucket of brine to measure total flow.

The ratio of product flow to total flow gives us the recovery rate, expressed as a percentage. If the percentage is below the minimum it indicates an internal leak in the Clark Pump. A Cape Horn system uses a 10% recovery pump, where 8% is the minimum acceptable recovery rate.

Flow Test - Cont.

On the Cape Horn Xtreme, you should perform the tests using each pump alone, then using both pumps. To run one pump, simply unplug the other pump. Compare the results to the table in the New System Startup section.

Minimum acceptable Product Recovery Rate = **8%** Nominal Total Flow Rate = **2.7-2.8 G/M**

1. Product flow: Product flow is expressed in Gallons Per Hour (GPH) or Liters Per Hour (LPH), by this equation:

$3600 \div \text{time in seconds} \times \text{quantity of water in gallons or liters} = \text{GPH or LPH}$
There are 3600 seconds in an hour.

Example: It took 3 minutes and 35 seconds to collect 1 gallon of product water.
 $3600 \div 215 \times 1 = \mathbf{16.74 \text{ GPH}}$ (3 minutes, 35 seconds is 215 seconds)

Example: It took 2 minutes and 25 seconds to collect 2.5 liters of product water.
 $3600 \div 145 \times 2.5 = \mathbf{62.07 \text{ LPH}}$ (2 minutes, 25 seconds is 145 seconds)

2. Total Flow or Feed Flow: Feed flow or total flow (brine + product) is expressed in Gallons Per Minute (GPM) or Liters Per Minute (LPM), by this equation:

$60 \div \text{time in seconds} \times \text{quantity of water in gallons or liters} = \text{GPM or LPM}$

Example: It took 1 minute and thirty-seven seconds to collect 5 gallons of total flow.
 $60 \div 97 \times 5 = \mathbf{3.09 \text{ GPM}}$ (1 minute, 37 seconds is 97 seconds)

Example: It took 53 seconds to collect 12 liters of total flow.
 $60 \div 53 \times 12 = \mathbf{13.58 \text{ LPM}}$

3. Recovery Rate: Recovery Rate = (Product Flow/Total Flow) x 100

Example: $\frac{14.5 \text{ GPH product flow}}{2.7 \text{ GPM total flow} \times 60} = .089 \times 100 = \mathbf{8.9\%}$
(you must first multiply total flow by 60 to convert from GPM to GPH)

In order to make good water, you need the proper amount of feed water flow. Each pump alone should produce 1.5 gallons per minute (5.7 LPM) of brine discharge PLUS product water (Total Flow = Product + Brine). Running on both pumps the flow should be 2.7 GPM (10 LPM).

Compare the product flow to the total feed flow. Product flow should be between 8% and 9% of total flow for a Cape Horn Xtreme. If product percentage is low, you may have an internal leak in the Clark Pump and it probably needs to be rebuilt.

For every $\frac{1}{10}$ th of a GPM feed water flow loss, we will lose about $\frac{1}{2}$ gallon (1.89 liter) per hour of product flow and the salinity will go up approximately 100 PPM.

Low feed flow combined with low system pressures is most frequently due to worn Shurflo pump heads (PL-PMP-SFPH) or low input voltage.

Troubleshooting Cape Horn Extreme 330 Remote Manual Systems

SYMPTOMS	PROBABLE CAUSE	REMEDY
Low product flow, more than 1 GPH, Total flow down (See Flow Test.)	Motor receiving less than 12.5VDC. A 0.5 VDC decrease at the feed pump motor can equate to a loss of 0.5 gallons (1.89 liters) product per hour. If possible, run diagnostic tests when the system is getting at least 13.2 VDC.	Check for voltage drop. Increase wire size if necessary.
		Check Power Supply.
		If available, turn on battery chargers.
	Blockage or restriction in the system.	Replace prefilter, service strainer, and check all hose runs.
	Thru-hull blockage	Confirm by using intake service hose and bucket of seawater to bypass thru-hull Clean thru-hull.
	Mineral scaling	Perform SC-3 Cleaning.  <i>Note: By design, it is rare for the membrane to cause low total flow on Spectra Systems.</i>
	Pump or Motor worn	Confirm by attempting pressure test (See Tech Bulletin). Strong pumps with good power should reach 125 psi within 3 seconds. Replace pump head.
Low product flow, Recovery percentage below minimum nominal value (See Flow Test)	Pressure Relief Valve open partially	Close pressure relief valve.
	Internal leak in Clark Pump	Complete service is recommended. Contact Dealer or see Clark Pump rebuild manual. Install Offshore Kit.
Asymmetrical pressure and flow readings between pump shifts — When one shift has 0 pressure	Internal leak in Clark Pump.	While system is running kink brine hose to stop flow until feed pressure rises to 115 psi, release hose quickly, repeat no more than 10 times.
		Inspect Clark Pump Check Valves.
Asymmetrical pressure and flow readings between pump shifts—more than a few psi	Scored Clark Pump annular rings and reversing valve spool	Replace.
	Scored Clark Pump piston rod and lip seals	Confirm by opening test port on back of pump. If constant flow, replace seals and circular sand (240 grit) or replace piston rod.
	Scored Clark Pump Cylinder(s)	Hone, circular sand (240 grit) or replace.
Display activates, but pump will not run	Loose or broken pump wire connection Tanks are full (if equipped with tank switch). If full, Run & Stop LED should be lit.	Check wiring at terminal block inside control box Check tanks— system cannot be started if tanks are full.



Troubleshooting Cape Horn Extreme 330 Remote Manual Systems

SYMPTOMS	PROBABLE CAUSE	REMEDY
No Product flow, good brine discharge flow. Recovery percentage is 0 (See Flow Test)	Internal leak in Clark Pump.	While system is running kink brine hose to stop flow until feed pressure rises to 115 psi, release hose quickly, repeat no more than 10 times.
		Inspect Clark Pump Check Valves.
		Complete service is recommended. Contact Dealer or see Clark Pump rebuild manual. Install Off-shore Kit.
Feed Pump not running, no noise	No Power At feed pump	Check voltage at feed pump.
	Pressure switch failed.	Adjust or bypass. To bypass, turn off power and pull off the 2 cables with push-on terminals and connect them together with a piece of electrical cable pushed into each terminal. Do not run the pump for long, just to diagnose failure.
Feed pump runs intermittently cycling on/off	Overpressure switch on Feed pump opening	Adjust or replace switch.
Feed Pump runs with loud noise	Intake blocked	Check Through Hull.
	Air in system	Check sea strainer for leaks.
		Check freshwater flush module for leaks.
		Re-prime system (restart).
Feed Pump turns on but no pressure	Feed Pump air locked	Open pressure relief valve to bleed the air then close to start
	Pressure relief valve open	Close pressure relief valve.
Feed Pump Starts but shuts down on high pressure	Prefilter excessively clogged	Change prefilter.
	Closed valve or blockage in flow	Check flow path for closed valve or kink in hose.
High Feed Pressure, High Amperage, and Product flow down up to 15%	Colder or more saline seawater	Normal Condition.
	Brine or product flow observing back pressure	Confirm by running both into a bucket.



Troubleshooting Cape Horn Extreme 330 Remote Manual Systems

SYMPTOMS	PROBABLE CAUSE	REMEDY
	Scaled or Fouled Membrane	Clean membrane.
Low Feed Pressure, Low Amperage	Warm seawater or brackish water	Normal Condition.
PPM rises steadily while pressure and production remain constant	Membrane needs to be replaced	Consult dealer and replace membrane.
	Feed flow or Clark Pump problem	Low product flow, recovery percentage or feed pressure can lead to drop in product water quality, perform Flow Test and address flow issue.
	Membrane was fouled or damaged	Clean membrane or consult dealer about membrane damage when product flow and pressure are at spec levels but water tastes salty.
	Fouled Prefilters	Freshwater flush procedure needs to be tested and adjusted. Replace filters or run watermaker for an extended period of time to rinse.
PPM High	<p>TDS meter needs calibration</p> <p>Feed Flow or Clark Pump Problem</p> <p>Membrane fouled or damaged</p> <p>Fouled Prefilters</p>	<p>Recalibrate TDS meter or taste test water until it can be replaced</p> <p>Low product flow, recovery percentage, or feed pressure can lead to drop in product water quality. Perform Flow Test & address flow issue.</p> <p>Clean membrane or consult dealer about membrane damage. If system flow (product plus brine) is to specification, the membrane is clean, the product flows are consistent with the system flow, and the water quality is still not acceptable, then replacement of the membrane is indicated. By design, high ppm typically has to do with something other than the membrane itself.</p> <p>Freshwater flush procedure needs to be tested and adjusted. PPM of brine discharge must be below 1000ppm at end of flush cycle. Replace filters or run watermaker for an extended period of time with pressure relief valve open to rinse.</p>



Technical Bulletins

Spectra High Pressure Fitting Instructions

The Cape Horn Xtreme has eight high pressure fittings, two on each cylinder on the Clark Pump, two on the pressure vessel end caps, and two 90-degree elbows on the back of the Clark Pump. As the compression fitting is tightened, it compresses a ferrule onto the stainless tubing, fixing the ferrule permanently to the tube and holding the compression nut captive.

The body of the fitting seals to the underlying component with an O-ring. On the Clark Pump cylinders and the end caps this O-ring is compressed by tightening the entire fitting. The O-rings on the 90-degree fittings on the back of the Clark Pump have captive nuts and washers, which compress the O-rings without turning the entire fitting.

If a tube fitting leaks it can sometimes be resealed by just tightening. You must use two wrenches, a 13/16-inch wrench to hold the base, and a 7/8-inch wrench to turn the compression nut. The 13/16-inch wrench will need to be thin so as not to interfere with the compression nut. If this doesn't work, disassemble the fitting, grease liberally with silicone grease (the ferrule and the threads) and re-tighten firmly.

The base O-rings should be **gently** compressed to achieve a good seal, and may be damaged by overtightening.

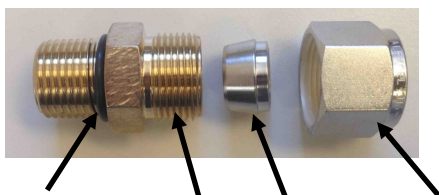

Connector O-ring

Ferrule

Stainless Fitting Hex Nut

Nickel-Bronze High Pressure Straight Fitting



Nickel-Bronze High Pressure Elbow

Technical Bulletins



NOTE: The following pages include Spectra's most commonly used technical bulletins, addressing tests, adjustments, troubleshooting, and common points of confusion. Many more technical bulletins are available on the Spectra website, support.katadyngroup.com.

DWYER FLOW METER SERVICE

The mechanical flow meter, PL-FMT-10 (10 GPH range) or PL-FMT-20 (20 GPH range) can be opened for cleaning if it becomes difficult to read or if the little ball gets stuck.

The flow meter will come completely apart for cleaning. First remove the meter from the panel. Remove the four small screws that hold the stainless steel bracket in place. Carefully wedge out the steel bracket. Above where the bracket was removed, there is a clear plastic slide-out. Use a flat bladed screwdriver to pull it out carefully. Once it is out, insert your flathead into the space it was removed from and gently nudge upwards to remove the top piece. Invert the flow meter and catch the ball as it falls out. You can use tooth paste or plastic window polish to polish the inside using a small bottle brush, or simply a q-tip. Clean the ball and give it a few coats of wax. If the O-rings are damaged or the unit has been leaking, install new O-rings using a little silicone grease to ease assembly. These are standard O-rings and should be available at most larger auto parts or bearing stores. Reassemble in reverse.

ACCUMULATOR PRESSURE

Your Spectra watermaker is supplied with a pressure accumulator tank (PL-ACC-TK), which should be installed in the feed water line between the prefilters and the Clark Pump.

The purpose of the feed line accumulator is to reduce the spikes in the feed pressure caused by the cycling of the Clark Pump. If the accumulator is not properly charged it can lead to problems with the Shurflo pump pressure cutout switches.



NOTE: The accumulator has a Schrader air valve, like a car tire, which allows the internal air bladder of the accumulator to be pre-charged. The accumulator should be pumped up to about 65 psi (4.5 bar) for best results. Add air using a tire pump or air compressor. You can experiment with the exact pressure that will give the best pulsation dampening on your installation.

Connections to feed water hose, between Shurflo pump and Clark Pump



Schrader Valve

PREFILTERS

It is important to remember that your Spectra Watermaker is designed to process clean, open-ocean seawater. Any departure from that standard for your seawater intake runs the risk of causing excessive wear or damage to internal pump parts and/or the vulnerable reverse osmosis membrane. Additional prefiltration considerations and/or extremely frequent prefilter replacements may be required in any deviation from open-ocean seawater. Your local service provider or installer may have specific recommendations based on their experience with water conditions unique to your region.

Observe the seawater around your vessel. Is it clean enough to use for your seawater intake? There are several things to avoid feeding to your watermaker:

- *petroleum products, such as oil, fuel, thinners, paints, paint removers, etc.*
- *chlorine-treated water; e.g., most “dock” water*
- *silty water — water contaminated by fine, hard, suspended particulates*
- *putrid water, “red tides”, or any seawater that smells or looks contaminated*
- *harbor/marina water that you cannot see through or that shows visible signs of contaminate (neighboring boats docked nearby may be discharging contamination! Sewage, chemicals, etc.)*

Judging the quality of seawater input always involves a certain calculated risk. We know of watermaker systems that have been destroyed far offshore by intaking fresh whale excrement or oil contaminants from natural seepages. The chance of such things happening is normally small but should be considered. On the other hand, **regularly running a watermaker in an enclosed marina or harbor runs a much higher risk of harmful contamination.** If you need to test a new installation while in a marina or harbor, monitor the water quality around your vessel carefully while testing. Often times you should be able to run the watermaker safely for enough time to briefly check out the system if you are mindful of external feed conditions. If this is not possible, an artificial ocean is a useful alternative (see Page 24 for artificial ocean testing/instructions). Don't sail away without testing a new installation or repair!



ATTENTION:

A Cape Horn Xtreme system uses two different filters to prevent damaging foreign materials from entering the system. A single 5 micron filter cleans the feed water of abrasive materials while the system is in operation; an additional carbon filter prevents the entrance of chlorine during fresh water flushing.

During normal operation, the feed water is filtered in two stages. First it passes through a fine mesh metal sea strainer, which protects the feed pump from foreign materials and sea creatures. After passing through the feed pump, the feed water passes the filter housing containing 5 micron element, removing very fine particles that could damage the Clark Pump and shorten membrane life.

Replacement schedules will vary widely depending on how and where the system is used. If large amounts of feed water are run through the system over a relatively short period of time in biologically fertile near-shore waters, the prefilter will plug up, water production and quality will drop, and the system pressure will change dramatically. If the pressure gauge was installed after the prefilters, as pictured on the plumbing schematic, the pressure will decrease as the filter becomes more clogged.

PREFILTERS CONT.

When operated for only an hour or two a day in inland or near-shore waters, the trapped plankton will begin to decay in the filter long before it plugs up. The decaying plankton and bacteria will cause a rotten egg smell in the product water. This decay will set in overnight in tropical waters, or after a week or two in higher latitudes. In crystal clear blue water conditions, the filters may need to be cleaned much less frequently.

If handled gently and changed regularly before they get too smelly, filters can be cleaned and reused several times.

Our filter element part number is FT-FTC-XX.

The last digits indicate the micron rating, e.g. FT-FTC-5 is for a 5 micron element:



CHARCOAL FILTERS

ATTENTION:

The charcoal filter element (FT-FTC-CC) removes chlorine from the fresh water flush water supply. The RO membrane can only handle small amounts of chlorine without permanent damage. If the fresh water flush water contains chlorine, the membrane will be exposed to it for days and will produce high salinity water.

The charcoal filter used for the fresh water flush system will not plug up unless you have very dirty domestic water in your boat's supply tank. About six months after installation the charcoal filter element will lose its effectiveness and must be replaced. This is purely a function of time.

The charcoal filter we supply removes 99.7% of the chlorine. Beware when buying other charcoal filters. If they don't specify the percentage of chlorine removed, don't use them. Cheap ones may remove only 60% or 70%. Also, there are aftermarket filters which are very close to, but not exactly the same dimensions, and will not seal properly in the housing. If you skimp on the charcoal filter you risk damaging a \$600.00 membrane on the first flush. The other factor is the flow rate that the filter can handle. Because the chlorine is adsorbed by the charcoal, it must remain in contact with the charcoal for a sufficient period of time for the all of the chlorine molecules to be captured. The filters we use can handle 1.5 gallons (6 liters) per minute flow, and are good for 3000 gallons (12,000 liters) at 1.5 GPM, or six months, whichever comes first. Regardless of the flow, the charcoal loses its effectiveness after six months.



Charcoal filter, Spectra part number FT-FTC-CC

SHURFLO PUMP WON'T RUN

If the pump has power to it but the pump won't run, first check the pressure switch. The pressure switch (EL-FP-PS) is located on the wet end of the pump and has two red wires plugged into it.



DANGER: Jump the two red wires together and see if the pump runs. You can safely run the system with the pressure switch jumped, just keep an eye on the pressure gauge and don't let system pressure exceed 110 PSI. Replace the switch when a spare is available. The pressure switch should never open unless there is a problem with the system or it is incorrectly adjusted. Check the accumulator pressure, the operating feed pressure, and the switch cut-out setting.

If the pump will not run with the pressure switch jumped then it is most likely a problem with the brushes or overheat protection switch inside the motor. The motor will come completely apart by removing the two screws on the end of the motor. Remove the rear cover and paper insulator. Pull out the plastic brush holder. The thermal switch is located on one of the brush leads. With an ohmmeter, check for continuity through the switch. If it is open, you can make temporary repairs by wiring around it, being careful that your new wiring doesn't chafe on the moving parts, nor resist the springs that push the brushes on to the commutator. The overheat switch is unlikely to fail unless the motor has overheated and shut down. Consider relocating the pump or improving ventilation if the overheat protection has failed.

If any corrosion is apparent the brushes may be sticking. Once apart clean all the carbon dust from all the parts. Clean the commutator with light sandpaper. Make sure to clean the small grooves on the commutator with a small sharp tool to remove the carbon in between the segments. Adjust the springs on the brush holders so the brushes slide smoothly in and out. If the bearings are rough and binding, remove the rubber dust cover and clean the best you can, grease them, and work them free by hand. Don't service the bearing unless absolutely necessary. Reassemble in reverse order. You can hold the carbon brushes back with papers clips inserted through the slots in the brush holder so they don't hang up on the bearing during assembly. Make sure the corrugated bearing shim doesn't push out, if it does, push it back into place.

ADJUST SHURFLO PRESSURE SWITCH

Shurflo feed pumps are equipped with a high pressure cutout switch (EL-FP-PS). This is the small black unit on the end of the wet end of the pump head (PL-PMP-SFPH) where the two red wires connect. If the pressure switch is not properly adjusted the pump may cut out each time the Clark pump cycles and the feed pressure spikes. When this happens the production will drop and salinity will increase. The points in the switch will fail quickly if set too low because of the constant arcing each time the Clark Pump shifts.

On the very center of the switch is a small 5/64" Allen screw. While running the system close the brine discharge seacock or kink the discharge hose, to block the flow. Watch the pressure gauge and adjust the pressure switch to shut off at 125 psi. Turn the Allen screw clockwise to increase the cut off set point.



Poor Product Water Quality

With any product water quality issue, you must ensure accurate calibration if you are using a salinity meter. For general quality evaluation, your taste is always good enough.

Membranes are not an exact science and two identical systems can have different product quality. World health standards deem water of up to 1000 PPM of total dissolved solids acceptable for drinking consumption. We consider anything below 750 PPM acceptable but not ideal, and anything below 500 PPM excellent. Factors that could affect water quality are addressed below.

LOW SYSTEM FLOW OR PRESSURE will equate to lower product quality (higher PPM).

Cape Horn Xtreme systems will produce slightly better quality water running two pumps, as this will create higher pressure and lower salinity. Worn feed pump heads or flow restrictions will cause lower feed pressure and higher salinity.

DAMAGE TO THE MEMBRANE by chlorine contamination. Flushing the system with chlorinated water will irreparably damage the membrane. Charcoal filters are used to absorb any chlorine which might be present in flush water. They must be of proper specification to be suitable. There is no test for chlorine damage except the process of elimination of other causes.



DANGER:

DIRTY OR SCALED membranes. A dirty (foreign material), scaled (mineral deposits), or contaminated (bacterial growth) membrane can result in poor water quality and abnormal operating pressures. If operating pressures are above normal, then cleaning is indicated. If the system pressures are within operating normal range, cleaning may have little result. Avoid cleaning as a diagnostic tool. Low water quality after storage with propylene glycol can usually be remedied by extended flushing or an SC-2 cleaning.

MECHANICAL LEAKAGE within the membrane pressure vessel. This is an unlikely but possible cause of poor water quality. A pinched or damaged O-ring within the pressure vessel, a scratch on the product tube on the membrane, a scratch within one of the end caps, or a seal fouled by contamination could allow sea water into the product water.



NOTE: *If system flow (product plus brine) is 2.7 GPM or above (1.6 GPM running one feed pump), the membrane is clean, the product flows are consistent with the system flow and the water quality is still not acceptable, then replacement of the membrane is indicated.*

Z-Ion Operation

The Z-Ion should be energized at all times, but will only consume power when operating. Upon initial power-up the LED will flash red/green and then will turn solid green.

Follow the instructions for Normal Operation and Fresh Water Flush. For treatment with the Z-Ion, the process is identical, only the Z-Ion will release silver and copper ions into the flush water when you turn on the generator with the on/off switch. Turn on the ion generator at the same time that you open the flush valve.

The operation cycle begins and the LED will flash green/amber. The cycle will continue until you turn off the ion generator or the adjustable timer times out (factory set for 15 minutes).

Turn off the ion generator at same time that you close the flush valve. If you forget to turn off the ion generator, the Z-Ion will time out after 15 minutes, so no harm will be done to the unit.

If the voltage is out of range, below 10V or above 56V, the LED will flash red every two seconds and the unit will shut down.

Each fresh water flush with the Z-Ion will protect your watermaker for up to 30 days, after which the process must be repeated.

After 720 cycles the service light on the front of the control box will light up, indicating that the probes on your Z-Ion may be wearing down, and should be tested. The service light is just a reminder, and the Z-Ion will go on functioning while it is lit.

 **NOTE** To reset the service counter, touch two magnets, at the same time, to the two red reed switches on the Z-Ion circuit board, labeled Switch 1 and Switch 2 below.

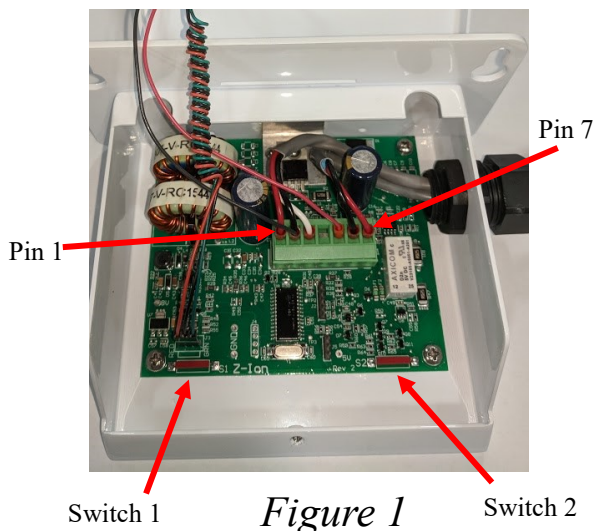

Figure 1

Z-Ion Operation – LED Status Lights & Pinout Info

- Power-up indication – *Fast red/green flash for a few seconds*
 - Ready/Idle – *Solid green*
 - Generating (during a flush) – *The LED will quickly flash at a programmed interval (factory set to 17 seconds between flashes) The flash color will alternate between green and amber and will be off in between voltage spikes. The color change symbolizes the polarity alternating from positive to negative.*
 - Bad power – *Fast red flash followed by shut down*
 - High temperature – *Fast red flash*
 - Service/Cycle Counter Limit - *Slow red flash*
- There are 7 pins on the phoenix connector from left to right in Figure 1.*

Pin 1 Supply Voltage- Battery (+)	Pin 4 Auxiliary Output 1
Pin 2 Ground	Pin 5 Auxiliary Output 2
Pin 3 Trigger	Pin 6 To Zion generator (bowl). No polarity.
	Pin 7 To Zion generator (bowl). No polarity.

Cape Horn Extreme Part Numbers

Feed Pump Module A, with charcoal filter for fresh water flushes

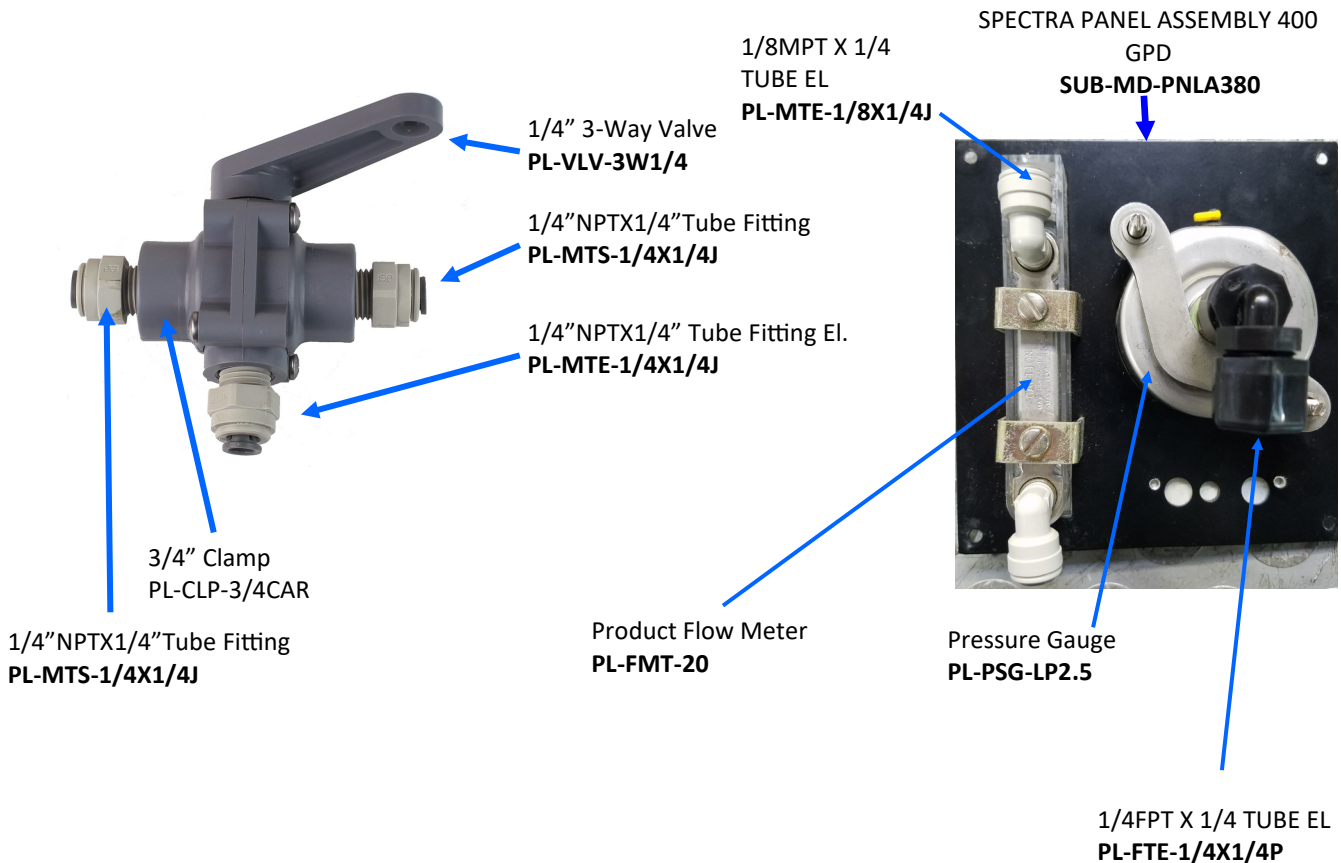
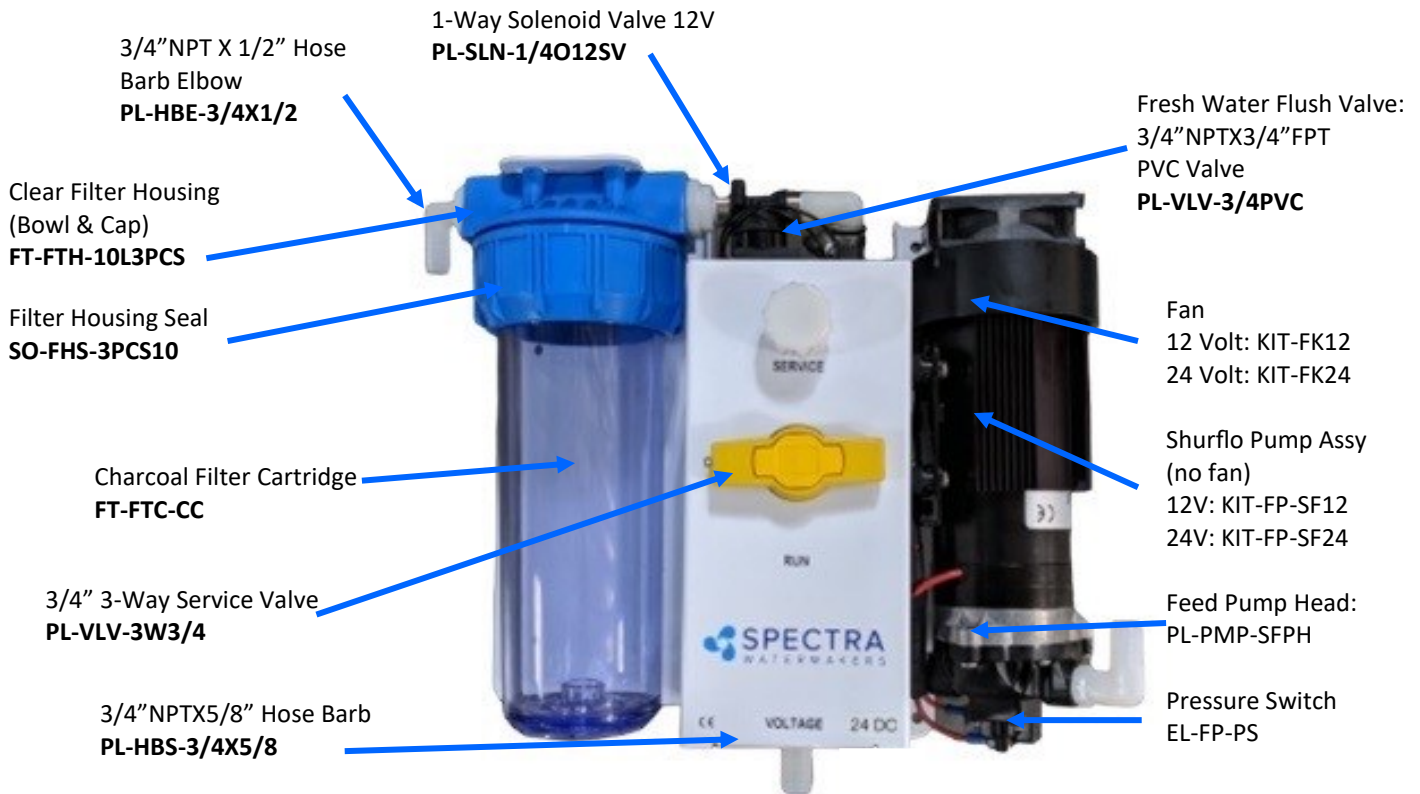

Cape Horn Extreme Part Numbers - Cont.

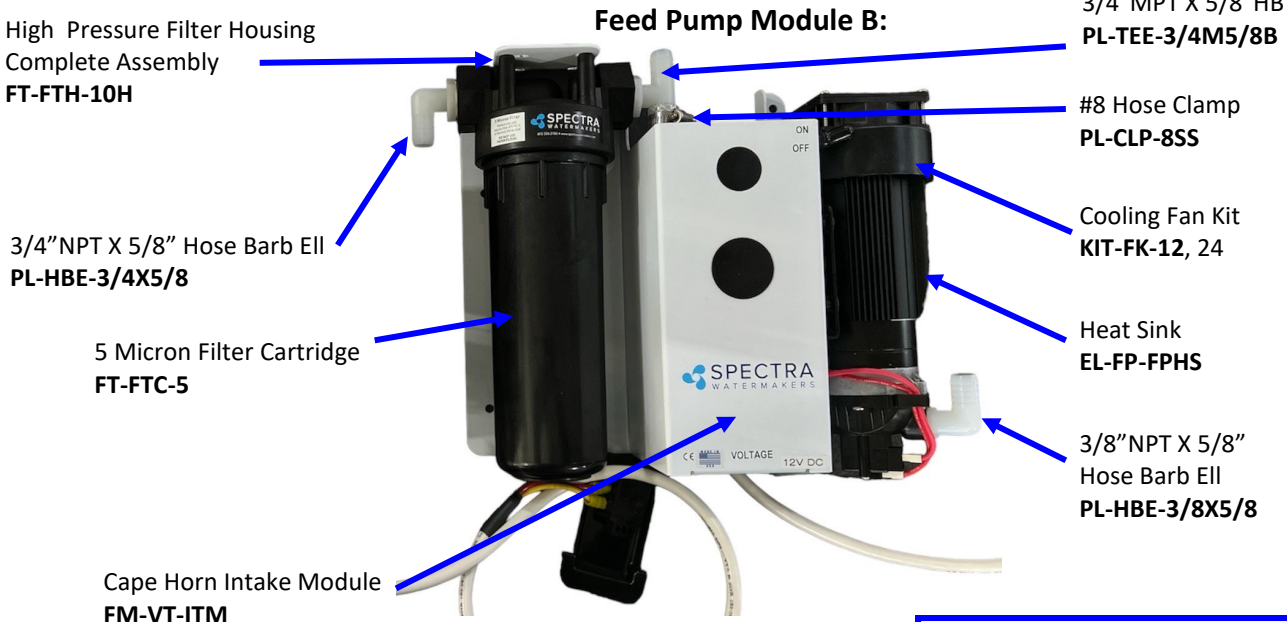
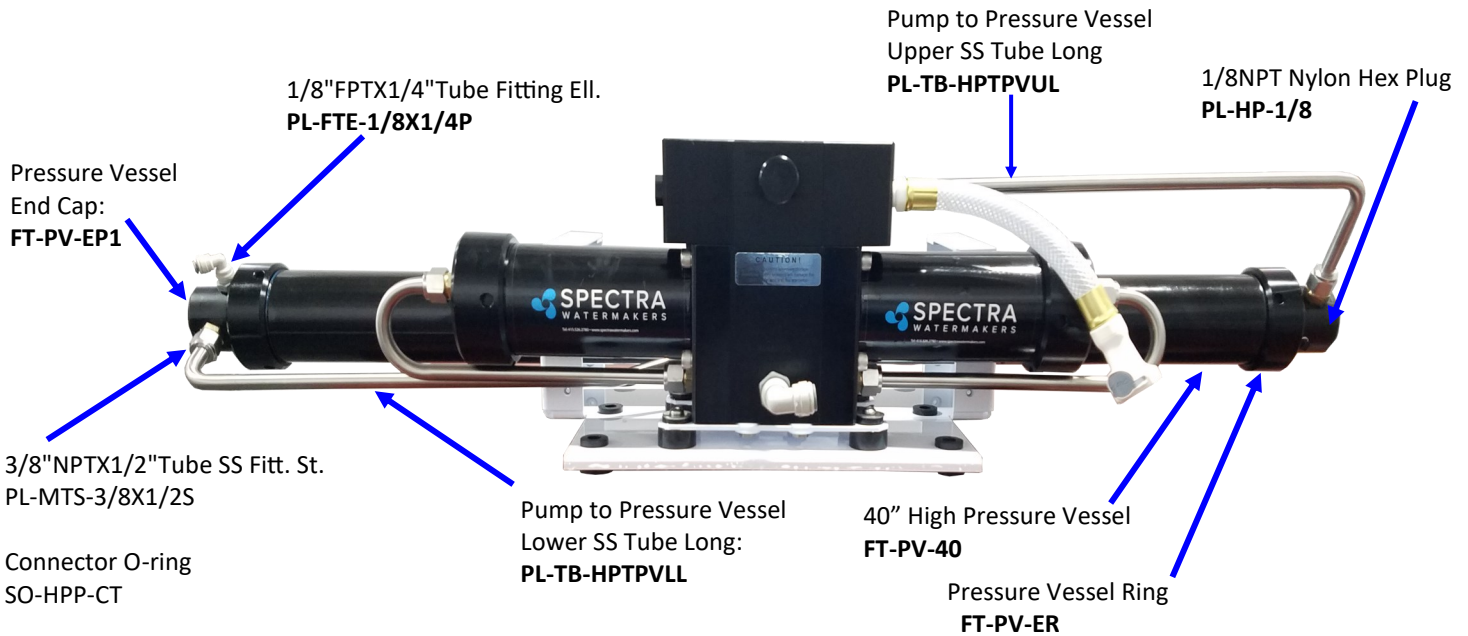

**Feed Pump Assembly
(Complete Pump With Heat Sink)
KIT-FP-SF12 or 24**



**Sea Strainer (Complete Assembly)
FT-STN-5**

Strainer Seal **SO-STN-5SS**

Strainer Screen **FT-STN-5S**

**Pump Head Assembly With Pressure Switch
PL-PMP-SFPH**

Pressure Switch **EL-FP-PS**

Shurflo Pressure Switch **KIT-FP-SFSK**

Cape Horn Extreme Part Numbers - Cont.

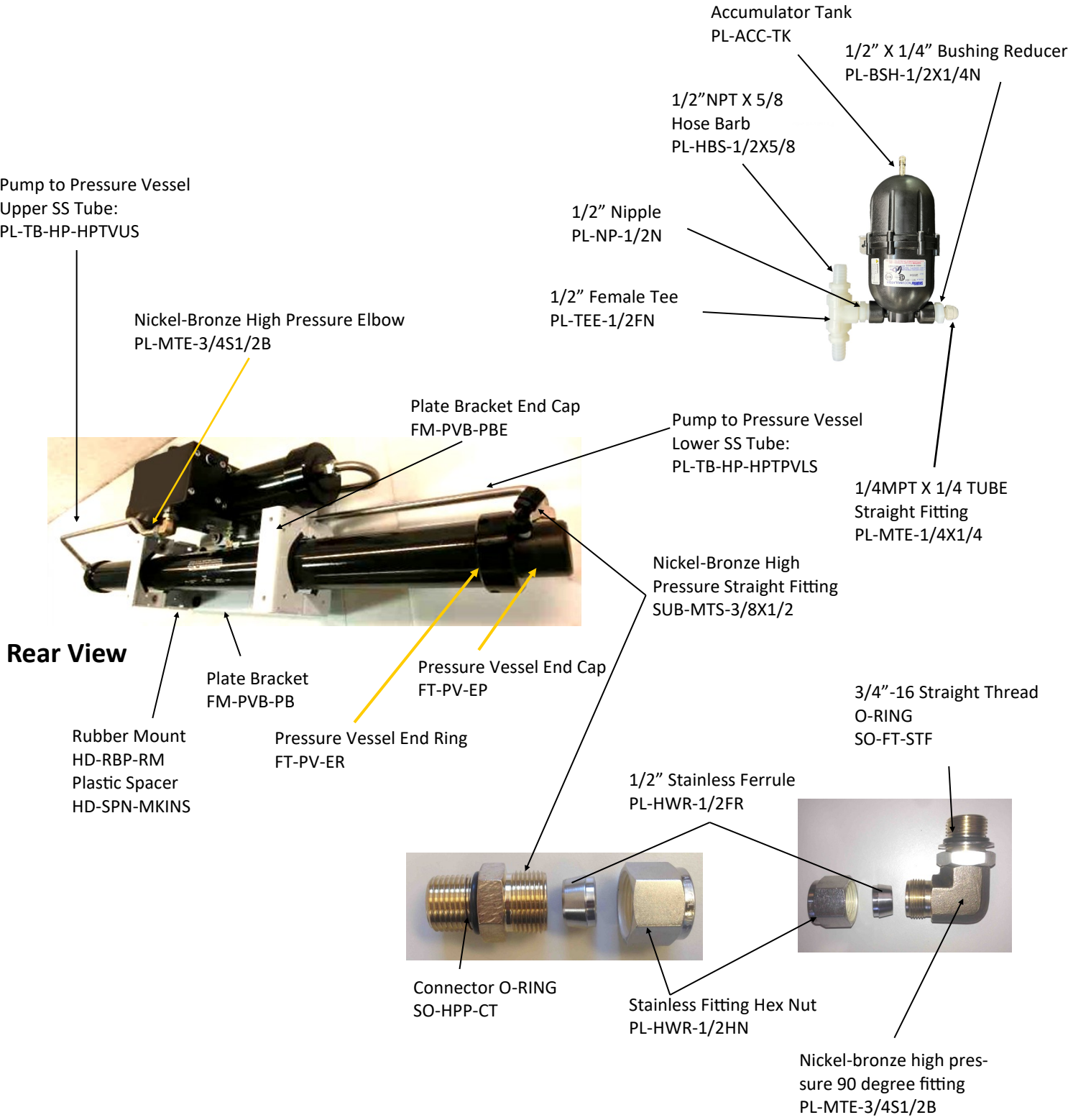

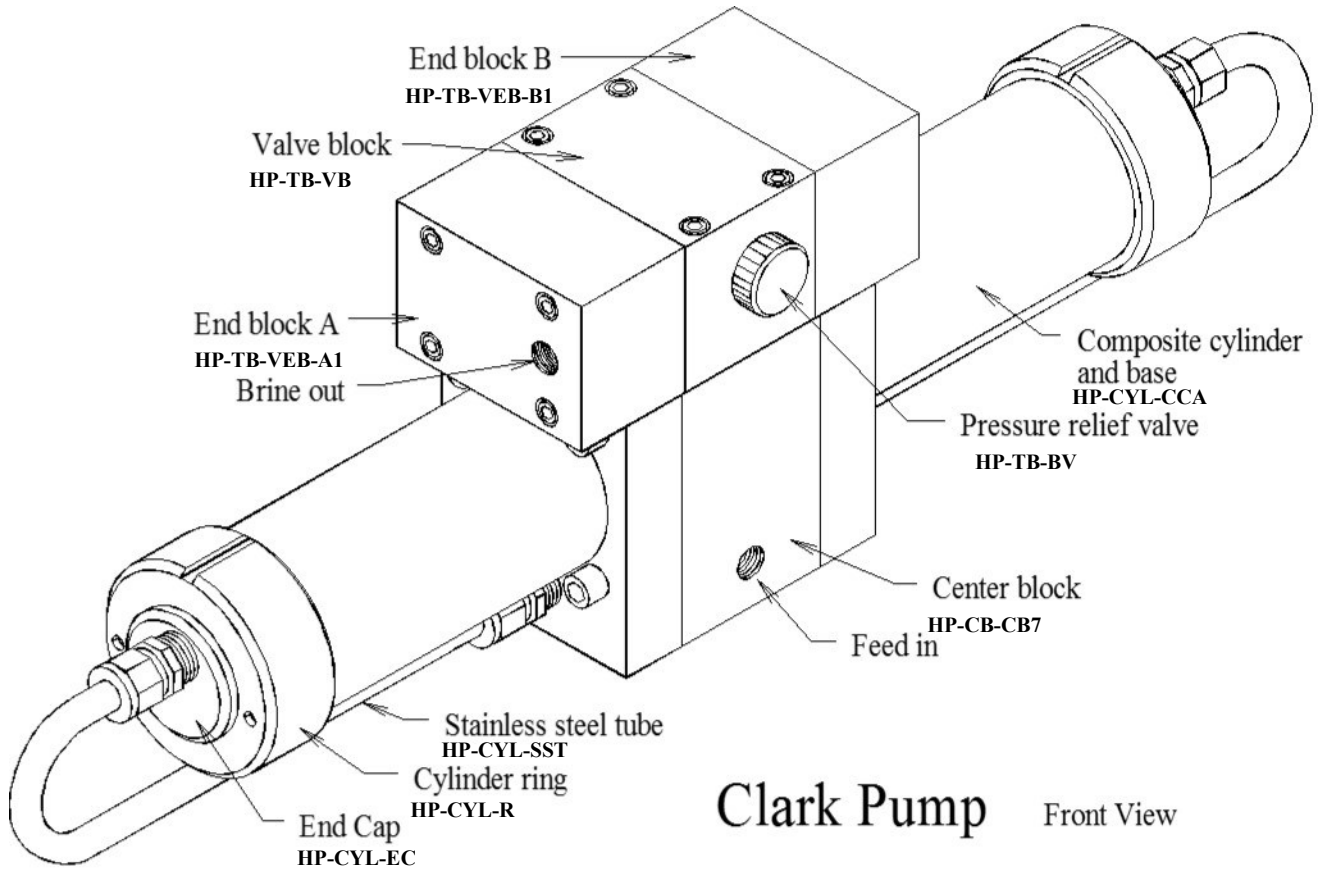

Clark Pump Front View

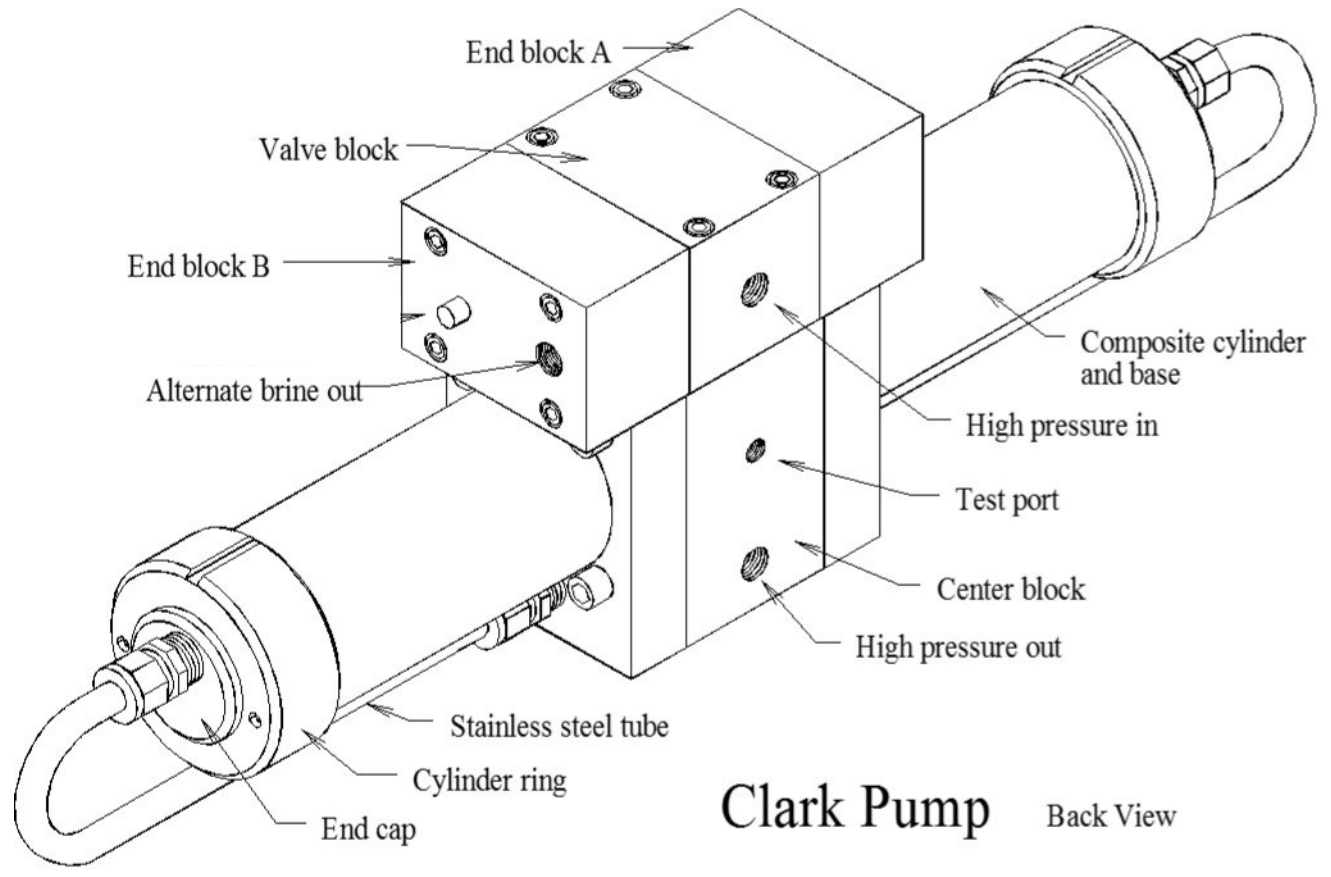

Clark Pump Back View

Spool Assembly
Exploded View

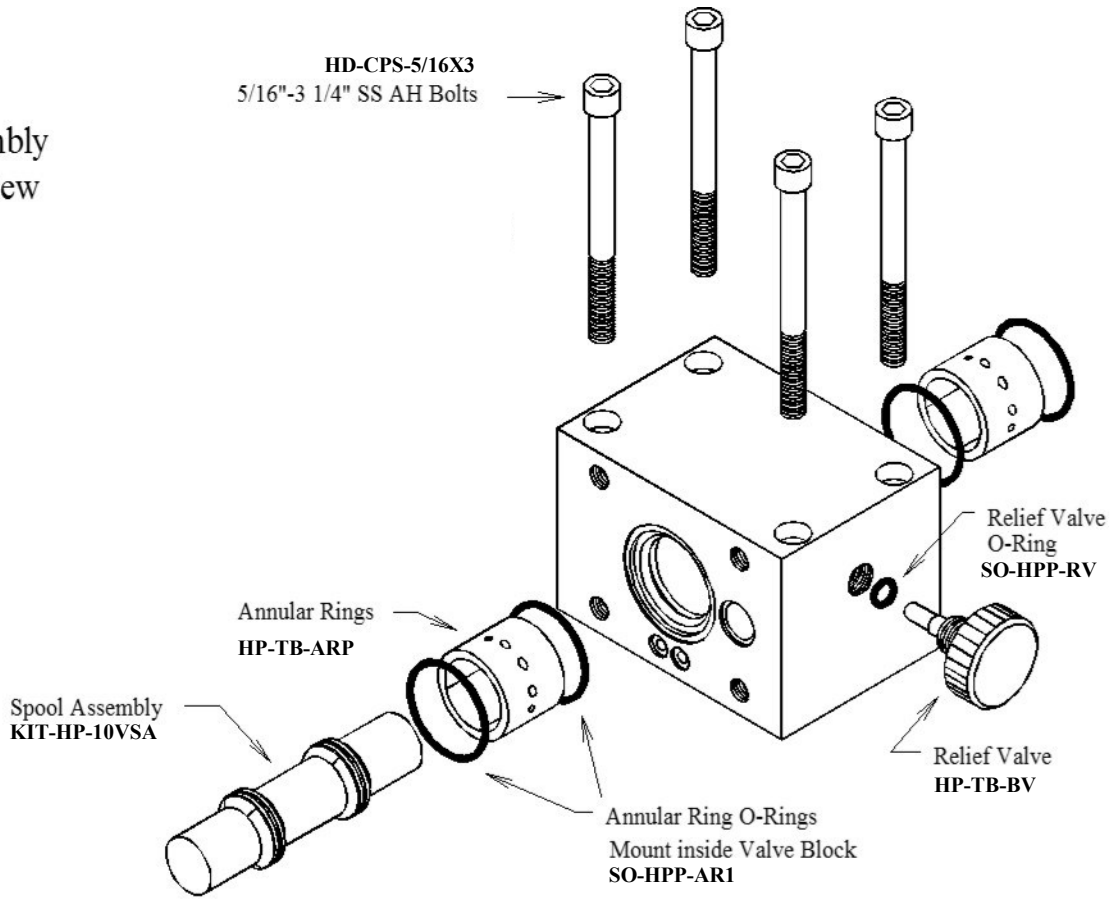

Valve Block

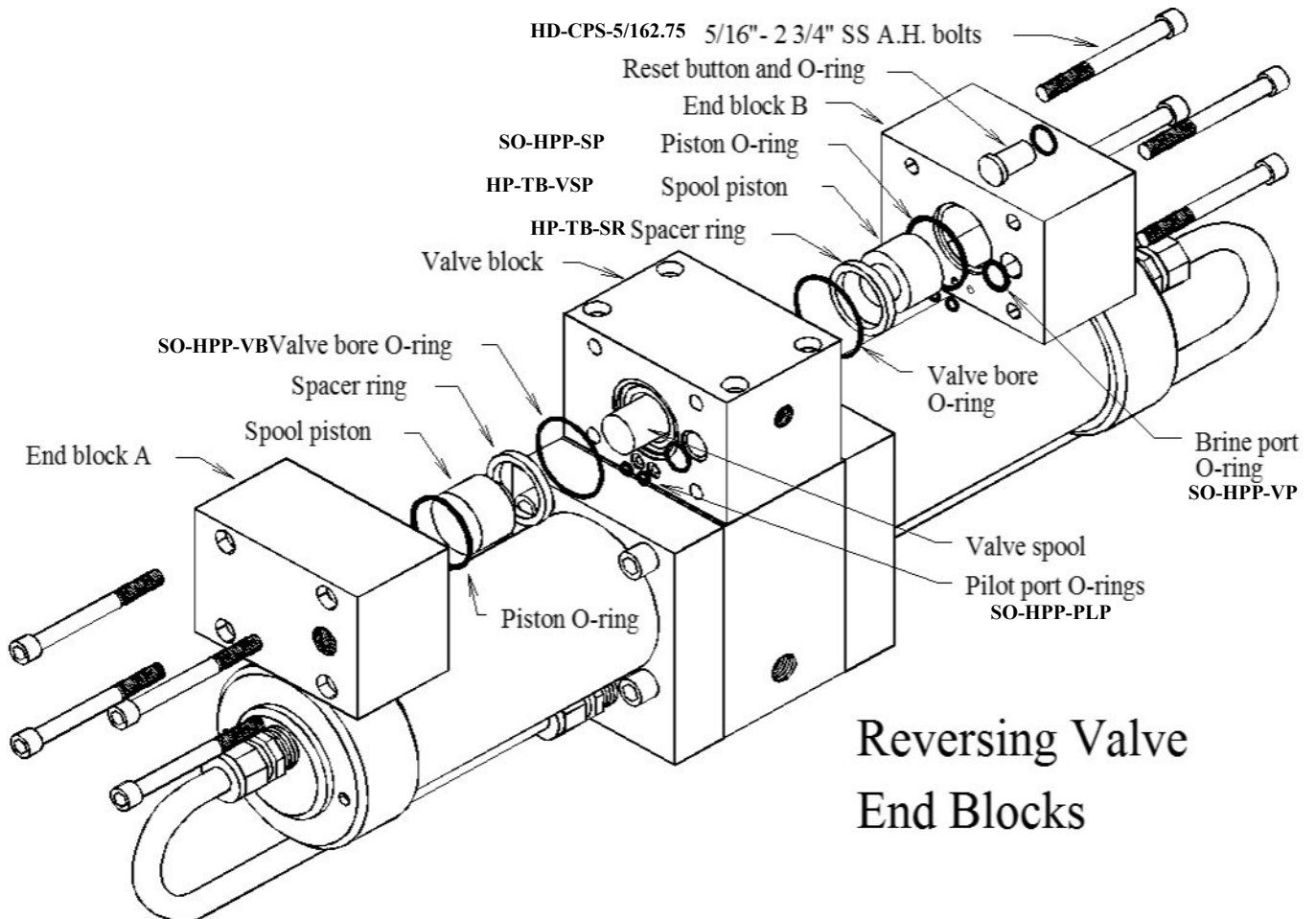

Reversing Valve
End Blocks

Parts

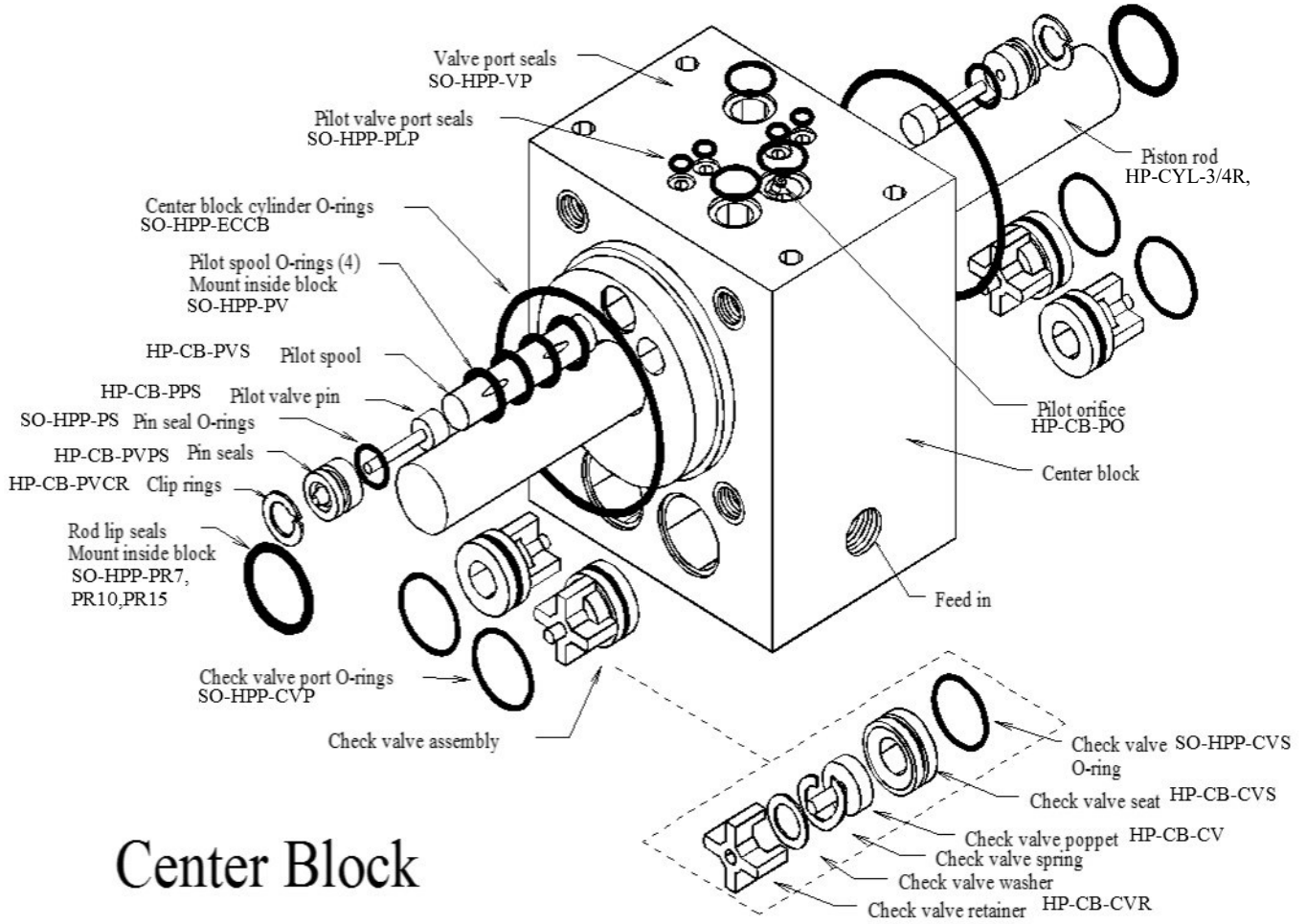

Center Block

Parts

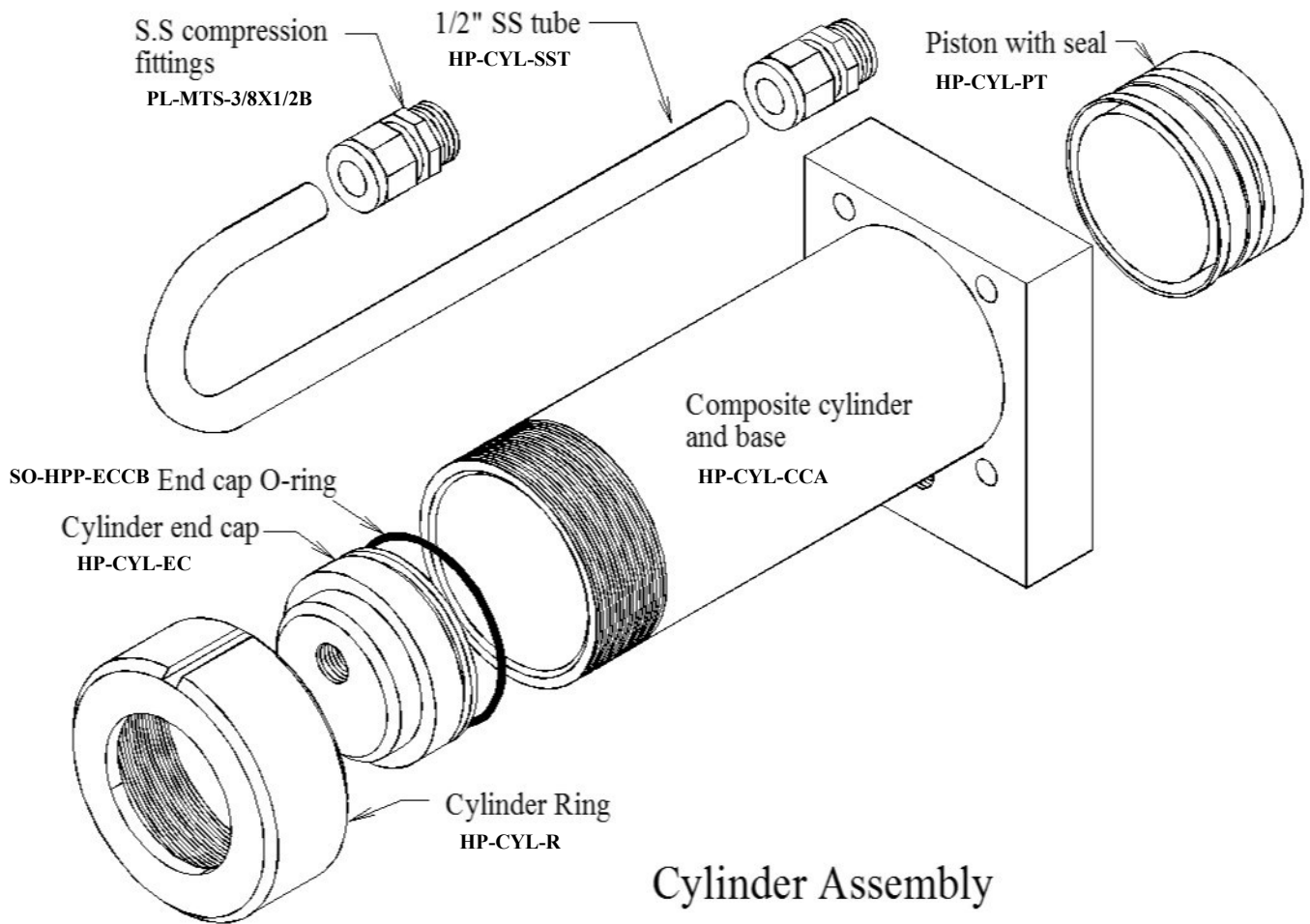

Owner Resources & Warranty

EXCITING EXTENDED WARRANTY OFFER!

-Upgrade the standard 1-YEAR manufacturer warranty to 2-YEARS and LIFETIME on Clark Pump.

Follow the below steps to submit for approval:

- 1. Have system installed & commissioned by Spectra Authorized FSP (full-service provider)**
- 2. Fill out web-based Product Registration form (see back of owner's manual for paper copy)**
- 3. Complete web-based install/commissioning form (see back of owner's manual for paper copy)**
- 4. Upon satisfactory review of required submissions, your 4-digit system serial number will receive an extra year of warranty coverage, and lifetime coverage on the Clark Pump!**

See 'Extended Warranty' section of owner's manual for full coverage details.



Spectra Product Registration Form

(To be completed by end user/owner)

https://spectrawarranty.formstack.com/forms/product_registration

Spectra Watermakers Commissioning Report

(To be completed by authorized installer)



https://spectrawarranty.formstack.com/forms/spectra_install_commissioning_report

Note: Offer & warranty criteria effective 1/1/2021. For purchases made in the EU, please see 'Expanded Warranty' section of warranty policy in back of the manual for EU specific coverage.

Spectra Watermakers. Making fresh water worldwide.

Spectra Watermakers is a Katadyn Group Brand.

KATADYN GROUP
SWITZERLAND

SPECTRA WATERMAKERS

SPECTRA WATERMAKERS LIMITED LIFETIME WARRANTY

THIS LIMITED WARRANTY APPLIES TO THE ORIGINAL OWNER OF THE WATERMAKER AND IS NOT TRANSFERRABLE

For warranty information regarding products sold within the European Union please contact [eu-
rope@spectrawatermakers.com](mailto:eu-
rope@spectrawatermakers.com).

This limited product warranty is provided by Katadyn Desalination LLC, a Business Unit of the Katadyn Group. (“Manufacturer” of “We” or “Our”) to the original, consumer owner of the product (“You” or “Your”) with which this limited product warranty is provided (the “Product.”)

The Manufacturer warrants to You that the product will be free from defects in material and workmanship under normal use and regular service and maintenance, subject to the exclusions described below, for a period of 1 year (the “Warranty Period”) after date of installation, or 15 months after the shipment date, whichever comes first. This warranty will be extended for an additional 12-month period when the product is installed and commissioned by a Katadyn Desalination Authorized Installer. A Spectra Watermakers Commissioning Report must also be returned and approved by the factory. The Spectra Clark Pump has a Limited Lifetime Warranty on Marine systems to the original consumer owner of the product, not inclusive of repair or replacement parts due to wear over time. If the Spectra Clark Pump is used in a Landbased application, the product warranty is provided for a period of 1 year (the “Warranty Period”) after date of purchase (if purchaser is installing system) or date of commissioning (if Spectra dealer is installing system).

You will be required to show written documentation supporting the date of purchase or date of commissioning. If you are unable to provide documentation supporting the date of purchase or commissioning, the warranty period shall be based on the product’s date code and will be determined by the Manufacturer’s sole and absolute discretion.

WHAT IS COVERED

Katadyn Desalination LLC. warrants, for the period defined above, that the Product will be free from defects in materials and/or workmanship and will conform to Manufacturers published specifications if installed and maintained in accordance with the Manufacturers Instructions.

WHAT IS NOT COVERED

The Warranty does not include service, repair, or replacement to correct damage caused by improper installation, maintenance, improper connection with water systems, external electrical fault, accident, alteration, misuse, abuse, neglect, negligence, (other than Manufacturer’s), acts of God, failure to install or maintain the product in accordance with the Manufacturers instructions.

DAMAGED OR MISSING PRODUCT

You must examine the Product upon receipt and notify Katadyn Desalination LLC. if any item is damaged or missing within 30 days from the date of the delivery. Damage due to freight must be reported to Katadyn Desalination LLC. and to the freight carrier within 24 hours of delivery.

SOLE WARRANTY

THE WARRANTIES SET FORTH IN THIS SECTION ARE THE SOLE AND EXCLUSIVE WARRANTIES GIVEN BY THE MANUFACTURER WITH RESPECT TO THE PRODUCTS AND ARE IN LIEU OF AND EXCLUDE ALL OTHER WARRANTIES, EXPRESS OR IMPLIED, ARISING BY OPERATION OF LAW OR OTHERWISE, INCLUDING WITHOUT LIMITATION, MERCHANTABILITY AND FITNESS FOR A PARTICULAR PURPOSE WHETHER OR NOT THE PURPOSE OR USE HAS BEEN DISCLOSED TO MANUFACTURER IN SPECIFICATIONS, DRAWINGS OR OTHERWISE, AND WHETHER OR NOT MANUFACTURER'S PRODUCTS ARE SPECIFICALLY DESIGNED AND/OR MANUFACTURED BY MANUFACTURER FOR YOUR USE OR PURPOSE.

WHAT WE WILL DO TO CORRECT PROBLEMS

If You return the defective product during the warranty period and in accordance with the instructions contained herein, shipping prepaid, the Manufacturer shall, at its option and as Your exclusive remedy, repair, correct or replace the product at no charge if the product is found by the Manufacturer to be a valid warranty claim, in Manufacturer's sole discretion. Replacement product may be refurbished and/or different models but will be functionally equivalent to the product or hardware being replaced. Product repaired or replaced during the warranty period shall be covered by the foregoing warranty for the remainder of the original warranty period or ninety (90) days from the date of shipment or purchase, whichever is longer. Contact your Dealer or the Manufacturer's Customer Service at 415-526-2780 to obtain a returns materials authorization (RMA #).

HOW TO MAKE A WARRANTY CLAIM

If You discover any warranty related issues after 30 days, or You have questions concerning Your product or how to determine when service is needed, please contact your local dealer or contact the Manufacturer's Technical Support at 415-526-2780 or email the Manufacturer at techsupport@spectrawatermakers.com. The following information must be provided as part of Your warranty claim: your name, address, phone number, Your products' model number, Your product's 4-digit serial number, and if necessary, upon request, written confirmation of the date shown on Your purchase receipt and the purchase price paid for the product. All products being returned to the Manufacturer must have a return material authorization (RMA) number to be processed. Any item returned to the Manufacturer without an RMA number will not be accepted by the Manufacturer. Contact your Dealer or Customer Service to obtain an RMA number. Once we have received Your returned product, we will determine, in our sole and absolute discretion, whether Your claim is covered by, or excluded from, this limited warranty. Repairs or modifications made to the product by other than the Manufacturer will nullify this limited warranty. Coverage under this limited warranty is conditioned at all times upon the original purchaser's compliance with these required notification and repair procedures.

LIMITATION OF LIABILITY TO THE FULLEST EXTENT PERMITTED BY LAW, IN NO EVENT, SHALL MANUFACTURER OR ITS AUTHORIZED SERVICE REPRESENTATIVES BE LIABLE FOR ANY INCIDENTAL, SPECIAL, INDIRECT, OR CONSEQUENTIAL DAMAGES, INCLUDING ANY ECONOMIC LOSS, WHETHER RESULTING FROM NONPERFORMANCE, USE, MISUSE OR INABILITY TO USE THE PRODUCT OR THE MANUFACTURER'S OR ITS AUTHORIZED SERVICE REPRESENTATIVE'S NEGLIGENCE. THE MANUFACTURER SHALL NOT BE LIABLE FOR DAMAGES CAUSED BY DELAY IN PERFORMANCE AND, IN NO EVENT, REGARDLESS OF THE FORM OF THE CLAIM OR CAUSE OF ACTION (WHETHER BASED IN CONTRACT, INFRINGEMENT, NEGLIGENCE, STRICT LIABILITY, OTHER TORT OR OTHERWISE), SHALL MANUFACTURER'S LIABILITY TO YOU EXCEED THE PRICE PAID BY THE ORIGINAL OWNER FOR THE MANUFACTURER'S PRODUCT.

The term "consequential" damages shall include, but not be limited to, loss of anticipated profits, business interruption, loss of use or revenue, the cost of capital or loss or damage to property or equipment. Some states do not allow the exclusion or limitation of incidental or consequential damages, so the above limitation may not apply to you. This limited warranty gives you specific legal rights, and you may also have may other rights which vary from State to State.

--- CUT HERE ---

Spectra Product Registration Form

Any commissioning/install report (and additional 12 month warranty) may be rejected at the sole discretion of Spectra Watermakers if the system is not installed correctly.

Registration (To be completed by owner)

System Details:

Model _____ Date of install: _____
 4-digit S/N _____ Clark Pump S/N: _____ Voltage _____
 Dealer/distributor: _____ Boat Location: _____ max speed: _____

Boat model or type (i.e. Leopard 44, Beneteau 55' powerboat, catamaran, powercat, 42' sailboat...)

What type of boating will you be doing and what will the watermaker primarily be used for:

Original Owner Details:

Name: _____ Phone Number: _____
 Email Address: _____
 Address (Optional): _____

Submission for Approval:

Please submit this document along with the Installation and Commissioning Reports to Spectra Watermakers for approval. Submissions can be **submitted online**, scanned and emailed, or mailed directly to the factory. Spectra Watermakers Technical Support will email the original owner and the authorized distributor with the status of submission.

Web-Based Format (Preferred option):

spectrawarranty.formstack.com/forms/product_registration
spectrawarranty.formstack.com/forms/spectra_install_commissioning_report

Email: TechSupport@SpectraWatermakers.com

Phone: +1(415) 526-2780

Address: Katadyn Desalination
 Technical Department
 2220 S. McDowell Blvd Ext
 Petaluma, CA 94954
 USA

Please keep a copy of these reports for your records.

--- CUT HERE ---

Spectra Watermakers Installation Report

(To be completed by authorized installer)

The following checklist is designed to confirm that the watermaker installation meets Spectra standards. Fill out the checklist as completely as possible. Check any boxes that apply and note any concerns. Please document any discrepancies or concerns with photos.

INLET

- Inlet Seacock is below waterline
- Inlet Seacock is dedicated
- Inlet Seacock is shared
- Inlet Thru-Hull forward facing scoop
- Has strainer
- Has diving snorkel
- Sea chest
- Other

Thru Hull Size: _____ IN/CM

Approximate location on vessel and notes: _____

FEED PUMP MODULE A

- Feed pump module is mounted upright
- Clearance for filter cartridge changes
- Intake hoses are free of kinks
- Pressurized domestic water is connected to carbon filter

Distance from waterline: _____ FT/M above /below the waterline

FEED PUMP MODULE B

- Feed pump module is mounted upright
- Clearance for filter cartridge changes
- Intake hoses are free of kinks

Distance from waterline: _____ FT/M above /below the waterline

HIGH PRESSURE MODULE and BRINE DISCHARGE

- Pressure relief valve is accessible
- Brine discharge has no obstructions and vents to atmosphere

Notes: _____

PRODUCT WATER TUBING

- Product water flows into top of freshwater tank
- Freshwater tank is vented

Notes: _____

INSTALLATION SIGN OFF

Technician's Name: _____ Date: _____

Technician's Signature: _____

Distributor/Dealer _____

Spectra Watermakers Commissioning Report – Page 1 (To be completed by authorized installer)

The following checklist is designed to confirm that the watermaker installation meets Spectra standards and that the system is performing at specification.

Fill out the below checks as completely as possible. Check any boxes that apply and note any concerns.

PURGE

- Storage Chemicals have been purged with PRV open

Length of purge: _____ Minutes

- Diversion Valve is up, in reject position
- Filter condition has been calibrated
- "Run Manual" switch engages full speed
- "Service" switch engages flush speed

RUN HIGH MODE CHECKS

Product Flow: _____ GPH/LPH

Confirmed Product Flow Rate _____ GPH/LPH

- Technician Flow meter. Brand _____
- Hand Measurement _____ Gal/Liters in _____ SEC/MIN

Product Quality: _____ PPM

- Confirmed product quality with handheld TDS meter

Feed Pressure: _____ PSI/BAR

Boost Pressure (with clean prefilters): _____ PSI/BAR

Brine Flow Rate: _____ GPM/LPM

Measurement taken with:

- Technician Flow meter. Brand _____
- Hand Measurement: _____ Gal/Liters in _____ SEC/MIN
- Boost Pump runs
- Output and motor speed decrease when low mode is engaged

Notes: _____

FRESHWATER FLUSH

- Freshwater Flush solenoid valve opens
- Feed Pump is not cavitating when system flushes with seacock closed

Ship's pressurized freshwater pump flow & pressure rating _____ GPM/LPM _____ PSI/BAR

When seacock is open, what is the ppm of brine discharge at the end of the flush _____

Flush duration is _____ Minutes

- Needed to change flush time
- Needed to change speed of feed pump during flush

Notes: _____

*If the system does not have a dedicated forward-facing scoop type thru-hull or will be on a vessel that moves faster than 15 knots the system needs to complete the following sea trial checks. Spectra Watermakers reserves the right to require a sea trial from any customer before approving a commissioning report.

SEA TRIAL

- Watermaker will flush while underway
- Watermaker will start while underway

While the vessel is underway moving _____ KNOTS/MPH/KPH the watermaker is producing _____ GPH/LPH at _____ PPM

Spectra Watermakers Commissioning Report – Page 2

OWNER EDUCATION

Owner has been trained on the following:

Know locations of

- Seacock/Thru-hull
 - Sea strainer Module
 - Feed Pump Modules A and B
 - Prefilter
 - High Pressure Module
 - Clark Pump Pressure Relief Valve
 - Product water inlet to Freshwater Tank
 - Sampling Tap
 - Brine Discharge location
 - Service hoses and storage chemicals
 - User Manual
-
- How to power the watermaker off and on at the main breaker.
 - How to run the watermaker.
 - How to freshwater flush and the importance of freshwater flushing.
 - Knows each pump can make water individually.
 - Knows when the ships domestic freshwater pump is on.
 - Knows which prefilter cartridges to use and how to change them.
 - Knows how to service the sea strainer module.
 - Knows where the carbon block filter is and is familiar with (6 months) service frequency.
 - Have visually seen the overboard brine discharge (Should know when the system is pumping water).
 - Knows how to sample the product water.
 - Understand when the Clark Pump is under pressure and cycling.
 - Have seen how the service hoses and bucket are used to circulate seawater or freshwater through the system.

Notes: _____

<p>COMMISSIONING REPORT SIGN OFF</p> <p>Technician's Name: _____</p> <p>Technician's Signature: _____</p> <p>Owner's Name _____</p> <p>Owner's Signature _____</p>
