

SPECTRA

Watermakers

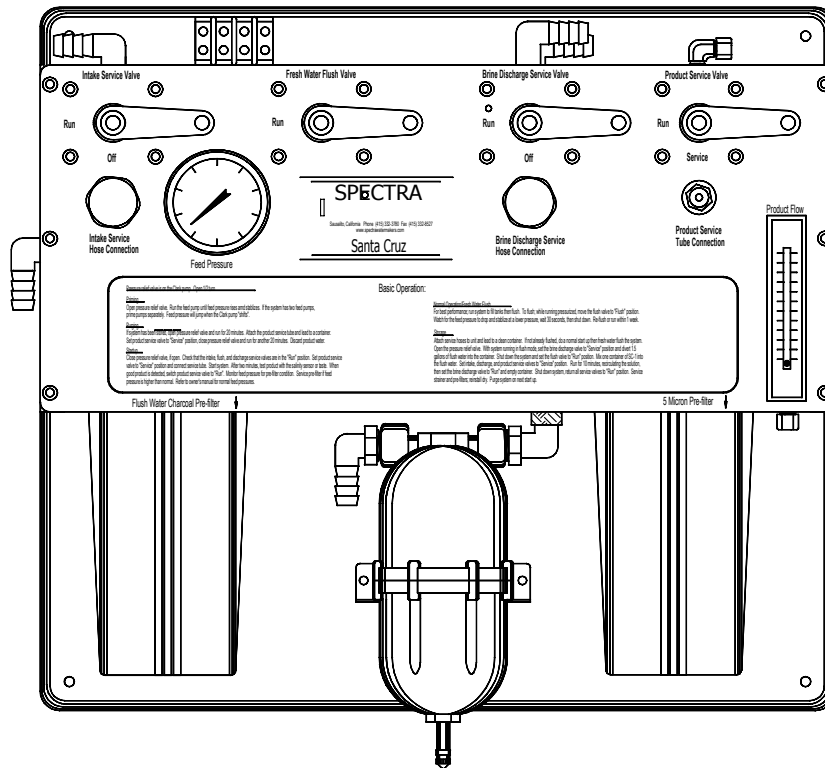

SANTA CRUZ OPERATION AND INSTALLATION MANUAL

Spectra Watermakers

A Division of Edinger Marine Service, Inc.

20 Mariposa Rd, San Rafael, CA 94901

Phone 415.526.2780 Fax 415.526.2787

E-mail: spectra@spectrawatermakers.com

www.spectrawatermakers.com

REVISED 03/20/02

Introduction

Thank you for choosing a Spectra Watermaker! It is our wish for you to be completely satisfied with our product. We have inspected and tested all of the components before shipping, and feel we have produced one of the finest products available.

Your long term satisfaction with this system will depend greatly on how the **Spectra** system is installed. The unique performance is obtained not only by our new pressurization process, but by careful attention to reducing flow restriction, mechanical friction and electrical resistance. All of this is affected by the final installation, and that is ultimately up to you. By reading, understanding and following this manual, even if you are not doing the installation yourself, we are confident you will be happy with your new **Spectra** system.

With years of experience installing and repairing many different kinds of watermakers, we have seen nearly everything that should or should not be done. This manual includes the summation of that knowledge, tailored for the **Spectra Watermakers**.

It is very important that you follow the instructions in this manual. They are designed to help you "customize" the installation to your boat, while maintaining performance. If any questions arise, please call us for help immediately. This is a unique product so be careful of "experts," as they most likely will not have gone through the same learning curve as we have during the development of the **Spectra** systems.

If someone else is installing the watermaker for you, review all aspects of the system with them before the drilling and cutting begins. This will help avoid making mistakes. If you have any doubts, please call us. We will be happy to help tailor the system to your particular needs. As with any sophisticated device, there may be "bugs" or minor problems. Please call us for consultation or advice before attempting to repair a new system.

"Use it or lose it" really *does* apply to watermakers, but we prefer "use it or pickle it". All watermakers will suffer damage if they are run and left without storage treatment or "pickling". We have found that if the pickling and cleaning processes are made easy there is a higher probability of it happening. This is why we have included service valves in the Installation Kit. Even though the system can work without them, they are very helpful in the servicing of your system.

In conclusion, having an adequate and reliable watermaker can improve the quality of life on board more than almost any other piece of equipment. It is our sincere desire that you will be able to take full advantage of your new **Spectra Watermaker**, confirming that you have indeed made the best choice! And don't forget to tell all your friends!

Thank you from all of us at **Spectra Watermakers**.

Table of Contents

System and Start-Up Log	page 4
Shipping and Shopping Lists	page 5
Features	page 7
Specifications	page 8
Component Description	page 9
Operating Procedures	page 12
Shutdown Procedures	page 15
Maintenance	page 17
Membrane Cleaning Procedures	page 18
Membrane replacement	page 20
Installation Basics	page 21
General Plumbing	page 22
Component Placement	page 24
Main Module Diagram	page 26
Clark Pump Diagram	page 27
Component Dimensions	page 28
Plumbing Diagram	page 29
Clark Pump Mounting Diagram	page 30
High Pressure Tube Instructions and Diagram	page 31
1/4" Tube Fitting Instructions Diagram	page 32
Clark Pump Mounting Template	page 33
Electrical	page 34
Wiring Diagram	page 35
Troubleshooting	page 36
Warranty	page 37

System and Start-Up Log

System Information

Model Number _____

Serial Number _____

Date Purchased _____

Purchased From _____

Installation Date _____

Start-Up Performance Readings

Measure after 3 and 24 hours of pressurized run time in similar conditions.

	3 hrs	24 hrs
Feed Water Temperature	_____	_____
Battery Voltage	_____	_____
Amperage Draw	_____	_____
Feed Pressure (psi)	_____	_____
Product Water Flow (gph)	_____	_____

Shipping List

Santa Cruz System

- (1) Operation and Installation Manual
- (1) Clark Pump
- (1) Membrane and Housing Assembly
- (1) Main Module including:
 - Pump and heat sink
 - Accumulator tank
 - Gauge and service valve panel
 - Manual fresh water backflush system
 - 5 micron pre-filter
- (1) Installation Kit Including:
 - Clark Pump mounting hardware
 - Membrane housing assembly mounts
 - Sea strainer
 - (10') high pressure tube
 - 50' of 5/8" hose
 - 25' of 1/4" product tubing
 - Hose and tube fittings
 - Hose clamps
 - One container of SC-1 storage chemical
 - Hand held salinity monitor

Options

- Clark Pump Mounting Bracket
- Basic Cruise Kit
 - Includes six 5-micron filters, and two SC-1 storage chemical containers
- Offshore Kit
 - Includes Clark pump seals, tools, two SC-2 cleaning chemical containers, and overhaul instructions
- Spare Feed Pump
- Dual feed pump system for more output

Shopping List

In addition to the installation kit.

Refer to manual for wire size and type of fasteners

Fasteners/Hardware for mounting components to desired surfaces.

Marine grade duplex wire, connectors and wire ties with mounts.

One, 2 gallon minimum, plastic mixing container.

One 15 amp fuse or circuit breaker switch

Tools Required

Wrench set to 7/8"

Adjustable wrench

3/8" drill, drill index and a hole saw set

Screwdrivers

5/16" nut driver for hose clamps

Wire cutter

Wire stripper

Electrical crimping tool for insulated connectors

Features

The **Spectra Santa Cruz** integrates the Spectra 200-C into a compact three module system that is the easiest of all our systems to install. It's light weight, compactness, low noise, and easy maintenance make it ideal for performance

sailing yachts. Powered by DC current, a generator set is not mandatory.

Using the patented Clark Pump and paying careful attention to system efficiency, the **Spectra Santa Cruz**, operates on a fresh water to power ratio that surpasses everything in the marine industry. The system makes an average of 9 gallons per hour on 9 amps @ 12.5v DC, less than *13 watt hours* per gallon! That means that making one gallon of fresh water is like running only a small DC cabin light for one hour!

The semi-modular design allows for easy installation. The feed pump, pre-filter, gauges, fresh water flush, and service valves are mounted together on a lightweight non-corrosive structure with an attractive gauge and service valve panel that has basic instructions printed on it. The Clark Pump and the membrane are mounted separately in any convenient location. The system's feed pump is self priming so the **Spectra Santa Cruz** can be up to ***4 feet above the water line!***

The production of fresh water is stable through the system's normal operating sea water temperature and salinity range. Only the working pressures change with the water conditions. A typical leading brand 200 gallon per day unit running in 61 degree F water will only make 140 gallons per day. The **Spectra Santa Cruz** will still be producing up to 200 gallons per day on a fraction of the power.

A manual fresh water backflush system with a charcoal filter to protect the membrane from chlorine and valve built into the panel is included standard.

Pressures are self-regulating, eliminating the need for adjustments, even when operating in brackish waters. The feed pressure is limited to 125 psi.

A self priming multi-diaphragm feed pump is all that drives the system. No additional boost pump is needed, or even helpful. A 5-micron pre-filter assembly is provided standard for maximum system life and reduced filter maintenance.

The system's noise level is exceptionally low and unobtrusive, especially compared to other systems of similar capacity. The feed pump has a smooth, steady sound and almost no vibration.

An installation kit is included.

Spectra Santa Cruz Performance Specifications

Sea water temperature @ 50° F (10° C):

Voltage	Feed flow	Feed pressure	High pressure	Amperage	Product
12.5v	1.5 gpm (5.7 lpm)	76 psi (5.2 bar)	650 psi (44.2 bar)	9.0	8.0 gph (30.0 lph)
13.8v	1.6 gpm (6.0 lpm)	82 psi (5.6 bar)	685 psi (46.6 bar)	9.6	9.5 gph (35.2 lph)
14.4v	1.7 gpm (6.4 lpm)	84 psi (5.7 bar)	700 psi (47.6 bar)	10.0	10.0 gph (37.8 lph)

Sea water temperature @ 77° F (25° C):

Voltage	Feed flow	Feed pressure	High pressure	Amperage	Product
12.5v	1.5 gpm (5.7 lpm)	64 psi (4.3 bar)	550 psi (37.4 bar)	8.0	8.3 gph (31.4 lph)
13.8v	1.6 gpm (6.0 lpm)	68 psi (4.6 bar)	570 psi (38.8 bar)	8.5	9.3 gph (36.0 lph)
14.4v	1.7 gpm (6.4 lpm)	70 psi (4.8 bar)	580 psi (39.4 bar)	8.8	10.0 gph (37.8 lph)

Sea water temperature @ 90° F (32° C):

Voltage	Feed flow	Feed pressure	High pressure	Amperage	Product
12.5v	1.5 gpm (5.7 lpm)	64 psi (4.3 bar)	530 psi (36.0 bar)	7.9	8.5 gph (32.2 lph)
13.8v	1.6 gpm (6.0 lpm)	68 psi (4.6 bar)	550 psi (37.4 bar)	8.4	9.5 gph (35.9 lph)
14.4v	1.7 gpm (6.4 lpm)	70 psi (4.7 bar)	560 psi (38.0 bar)	8.9	10.3 gph (39.0 lph)

Sea water salinity @ 35,000 parts per million TDS

Salt rejection: 99.0% ~99.4% Typical purity test: < 400 mhos, 200 ppm, 99.4% pure

Performance Tolerance +/- 10%

Maximum Operating Temperature 113° F (45 degrees C)

System Specifications

Weights and Dimensions:

Clark Pump	18.0 lbs. (8.18 kg)	27.25" (69.2 cm) L	8.25" (21.6 cm) H	6.5" (16.5 cm) D
Membrane	13.0 lbs. (5.91 kg)	43.5" (110.5 cm) L	3.5" (8.9 cm) Dia.	
Main Module	24.0 lbs. (10.9 kg)	21.5" (53.9 cm) W	18.25" (46.4 cm) H	6.6" (12.8 cm) D
Strainer	.5 lbs. (0.23 kg)	3.5" (8.9 cm) W	5" (12.7 cm) H	2.75" (7.3 cm) D
<u>Hose & Fittings</u>	<u>3.5 lbs. (1.60 kg)</u>			
Total weight	59.0 lbs. (26.82 kg)			

Component Description

Clark Pump

This is the heart of the system. The Clark Pump uses two opposing cylinders and pistons that share a single rod through a center block. A reversing valve, controlled by a pilot valve that is actuated by the pistons, allows the cylinders to alternate between driving and pressurizing. Pressurization is achieved by the rod being driven into the other cylinder. As the rod enters the cylinder, it pushes the piston which circulates the water out through the membrane and back to the reversing valve. The valve directs the water back into the same cylinder behind the piston, creating a *closed loop*. The rod displaces water as it enters the cylinder, raising the pressure enough for reverse osmosis to occur in the membrane, thus fresh water equal to the volume of the rod is produced on every stroke. The driving cylinder has feed pressure pushing on the top of the piston which has ten times the surface area than in the end of the rod. The water under the piston (brine) is discharged overboard. This gives the piston a 10-to-1 advantage over the rod, allowing it to drive the rod into the pressurizing cylinder. When the piston bottoms out on the center block, it actuates the pilot valve and the process is instantly reversed. High efficiency is achieved because there is no "back stroke," allowing one cylinder to always be under pressure.

The speed of this process is determined by the water flow from the feed pump. The feed pump has a nearly constant flow rate at a given voltage so the production of fresh water is nearly constant, only the pressures change with changes in sea water temperature and salinity. (see "Membrane" section)

A pressure relief valve and a reset button are incorporated in the Clark Pump to depressurize the system for priming and service and resetting the reversing valve if the Clark Pump is inadvertently stopped with the pilot and reversing valves at dead center.

Reverse Osmosis Membrane and Housing

The "RO" membrane element does the real work. A semi-permeable membrane and a capillary layer are attached and wrapped around a center catch tube then encased in fiberglass. The ends of the windings are open, allowing water to freely pass through from end to end. It is installed into a high pressure housing that directs the pressurized salt water to flow through the membrane and lets the product (fresh) water escape from the center catch tube. Threaded ports are provided for hose connections in the end caps of the pressure housing.

Approximately 85 gph of high pressure salt water flows *across* the membrane layer as 8.5 gph of fresh water is forced *through* the membrane and lead by a capillary layer to the catch tube. The excess salt water flowing out of the membrane is approximately 1/10th saltier and is called "brine." No salts are collected in the membrane. Membrane function is affected by sea water temperature and salinity. The warmer or less salty the water, the easier it is for the fresh water to pass through the membrane. This means that since the water production of the **Spectra** systems are nearly constant, warmer water lowers the operating pressures. The membrane is carefully sized to handle typical sea water temperatures and salinity, keeping the pressures within limits.

Main Module

***The following 7 items are pre-installed in the Main Module**

Note: The main module components are pre-plumbed and wired at the factory. All installation plumbing connections are made to the outside. Main power wiring connections are made to the terminal block at the top of the back panel. If further access is needed, the face panel is removable. By removing the six mounting screws, disconnecting the tube and hoses, the panel can be pulled clear .

***Feed Pump**

The feed pump is simply a self priming, multi-diaphragm, pump designed to run at pressures up to 125 psi. It is wired directly to the ships power through a 15 amp breaker or a fuse and switch. The system can be run directly off charged batteries without having a charging source running at the same time. Feed pressures average about 70 psi and the power draw averages 8.5 amps per hour. The high pressure cut out switch are is factory set at 125 psi. The optional duplex system allows for almost double the output. The second pump mounts where the accumulator is and the accumulator is mounted separately.

***5 Micron Pre-filter**

The pre-filter does the essential job of cleaning the sea water before it gets to the Clark Pump and R.O. membrane. Replaceable pleated fiber filters are used. Filter maintenance is crucial to the efficiency and life of the system. Five micron filtered sea water is important. A reverse osmosis system running on 5 micron filtered water will last much longer than one running on only 20 or 30 micron filtered water.

***Accumulator Tank**

The accumulator tank is an air chamber divided by a rubber diaphragm. The top chamber is pressurized with air to 10 psi below the expected feed pressure. For example, if the feed pressure is 70 psi, the tank should be pressurized to 60 psi when the system is off. When running, feed water will enter the lower chamber until the pressures equalize. Its function resembles a cushion to smooth out the feed pressure spikes when the Clark Pump “shifts.” This will extend the life of the feed pump and quiet the shifts between strokes.

***Feed Pressure Gauge**

The feed pressure gauge is an indicator of system operational status. Higher than normal pressures indicates the need for pre-filter service.

***Product Water Flow Meter**

The product water flow meter indicates the flow in gallons per hour. The reading is taken at the middle of the indicator ball.

Component Description, cont.

***Service Valves**

The service valves are in the feed, brine discharge, and product lines to provide easy

access for proper maintenance. The service hoses attach to the panel face and are lead to a cleaning container. **IMPORTANT: The intake and discharge service valves will close off all the ports if the lever is moved to the “Off” position.** The product service valve cannot close the ports when the lever is moved half way. This precludes the possibility of blocking the product flow and causing an over pressure condition that could burst the tube.

***Manual Fresh Water Backflush System**

The manual fresh water backflush system allows the operator to flush the system of salt water before it is shut down. The system incorporates a charcoal filter to remove chlorine when fresh water is drawn from the tank and a three way valve in the panel. When flushing is desired, the valve is turned to let charcoal filtered fresh water into the feed system and the feed pressure is watched for a pressure drop. When the feed pressure drops and stabilizes the system can be shut down. Replace the charcoal filter every 6 months.

The pressure relief valve does not have to be opened during flushing because the Spectra’s unique high pressure system will not generate membrane damaging excessive product flow when brackish or fresh water is introduced into a pressurized system.

Sea Water Strainer

The strainer filters the salt water to the feed pump. It has a cleanable, fine mesh, stainless steel element. The filter mesh is sized to stop debris that could jam in the pump’s check valves. *A coarse strainer should not be substituted.*

Installation Kit

The installation kit includes 50 feet of 5/8” reinforced non-toxic feed and discharge hoses, 10 feet of 1/2” high pressure tubing, 25 feet of 1/4” plastic product water tubing, standard mounting brackets, and all of the required fittings and hose clamps for most installations.

Mounting Bracket (optional)

The mounting bracket is a powder-coated aluminum “L” bracket for easy bulkhead mounting of the Clark Pump. Two brackets can be used for overhead mounting.

Basic Cruise Kit (optional)

The kit includes three 20-micron and three 5-micron filters and the SC-1 storage and scale cleaning compound (pickling) for 2 storage procedures.

Offshore Kit (optional)

The kit includes all seals and o-rings, composite valve sleeves, field tools and rebuild instructions for the Clark Pump and the SC-2 alkaline membrane cleaning chemical compound.

Operating Procedures

New System Start-Up

Caution: Avoid running the system if the vessel is in contaminated water, such as in a harbor or canal. Membrane damage and pre-filter clogging may result. Move the vessel to cleaner water. If the boat cannot be moved, first run the system with the fresh water flush valve on “flush” and the pressure relief valve open for 30 minutes. Close the pressure relief valve and continue flushing for another 30 minutes with the product water diverted. This will flush the storage solution from the membrane. Add water to the ship's tank if necessary. The system can now be run using a clean source of sea water in the cleaning container. Unchlorinated fresh water mixed with sea salt can also be used. Use the intake, brine, and product service hoses to recirculate the salt water to and from the container.

1. Check battery voltage. A nominal 12.8 VDC to 14.4 VDC should be indicated.
2. Confirm that the intake thru-hull is open and the strainer is clear.
3. Have the intake and brine discharge service valves in the normal run position and the product service valve in the “Service” position. Direct the product service tube to a container or into the bilge.
4. To prime the system, open the pressure relief valve on the panel face 1/2 turn and start the feed pump. Listen for the feed pump to prime itself and the Clark Pump start to “shift.” Check the brine discharge for water flow. Check the feed pressure, about 15-20 psi should be indicated **between** shifts with the pump running and the system unpressurized.
5. Check the feed pump high pressure cut out switch set point. With the system primed and running unpressurized, block the brine flow by moving the brine discharge service valve lever to the “Off” position. This will stop the water flow and cause the feed pump to shut off. Check the feed pressure gauge, it should be holding steady at about 115 to 125 psi. The pressure can be adjusted by tightening (higher pressure) or loosening (lower pressure) the Allen head set screw on the pump switch using a 5/64” Allen wrench. The accumulator tank will have to be moved for access. Now is a good time to check for leaks in the feed and brine connections as they are now pressurized to maximum.
6. Run the system unpressurized for 30 minutes after start-up to purge the pickling solution in a new membrane.
7. Close the pressure relief valve to pressurize the system and watch for the feed pressure to rise. Re-check the whole system for leaks, especially the high pressure hose connections. If any are found, turn off the system and repair them before continuing. Run the system under pressure for at least one hour while rejecting the product water. Compare the voltage, feed pressure, water temperature and amp draw to the specification table. The feed pressure should not spike more than 5 to 10 lbs. over normal when the Clark Pump shifts and should stay under 85 psi at all times. The feed pump should never be allowed to cycle the high pressure cut out switch on and off during the shift. The pump sound should remain almost steady. If the pressure spikes are high and/or the pump stops momentarily during the shift, check the high pressure cut out set point and/or check the accumulator pre-charge.
Operating Procedures, cont.
8. After one hour, test the product product water with the salinity monitor and taste. If the

water is good, the service valve can now be switched the “Run” position to direct the flow to the water tank.

9. At three hours of pressurized run time, and again at 24 hours, re-check for leaks and take note of the system feed pressure, product flow and amp draw, compare them to the specification page and enter them into the start up log.

Normal Start-Up

1. For normal start-up (meaning the unit has been run within the last 3 days) move the product valve to the “service” position to divert the product and start the system. Close the pressure relief valve if it is open.

2. If air is in the system and the feed pump has lost its prime, open the pressure relief valve to allow the feed pump to re-prime itself. Check for air leaks in the feed hose to the pump.

3. After starting and pressurizing the unit, check for leaks and wait for it to stabilize, then check for proper readings (**see Specifications, page 8**). Air in the system will cause erratic shifts and readings until it is purged out of the system. This may take up to 10 minutes.

4. Check the product water with the hand held salinity monitor or taste test. If good, switch the product service valve to the “run” position to start filling the tanks.

Warning!

On start up, if the feed pressure keeps rising until the feed pump shut off and the Clark Pump is not shifting, depressurize the system and press the reset button on the side of the reversing valve on the Clark Pump, *all the way in*, to unstick the system. To avoid a stall condition, always turn off the system right *after* the Clark Pump “shifts”. Also check that the service valves are in the normal run position.

Pickled System Start-Up

If the system has biocide in it (also known as “pickling” or storage solution), open the pressure relief valve 1/2 turn. Attach the product service line and lead to a container or into the bilge. Switch the product service valve to the “Service” position to manually reject any product water and run the system unpressurized for 30 minutes to purge the biocide. Close the pressure relief valve to pressurize the system. Run for another 30 minutes, test the water, then switch the product service valve back to the “Run” position.

Unknown Condition Start-Up (CAUTION: Do not start the system yet!)

If the system has been left unpickled for an extended length of time or the history is unknown, perform this simple test **before** running the system:

Open the pre-filter and inspect its condition. If the filter is black and smell bad, that’s one indication that the system is fouled. Install a new or cleaned pre-filter. Attach the brine discharge service hose and place it into a container and move the brine discharge service valve to the “Service” position. Open the pressure relief valve and start the system. Watch the brine

Operating Procedures, cont.

that first comes out. If the water is discolored and smells bad, perform an SC-2 cleaning on the system before pressurizing (see cleaning instructions). Pressurizing a system with a fouled membrane will compact the biological growth into the membrane and make it harder to clean.

If the water is only slightly discolored and smells OK, perform a *Pickled System Start Up*. Compare the system readings to the performance specifications to see if the system is performing properly.

Normal Operation

Spectra Watermakers are designed to run continuously with only pre-filter maintenance performed as necessary. Ideal performance is achieved by running the system until the tanks are full, do a fresh water flush, then turn off the system,

In moderate climates, if the membrane is mounted in a cool place, it is not necessary to flush the system every time if the unit is used once every one to two days. Flush the system if it's not going to be operated for more than two days and up to one week. Flush the system after every use in hot conditions. Pickle the system if longer periods of non-operation are expected.

Running the unit during charging cycles will produce more water because of the higher voltage (see Performance Specifications). System readings should be periodically checked and compared to the start-up log readings and performance specifications. Look for asymmetrical readings and listen for any change in the sound of the system that may indicate potential problems.

If too much air is introduced into the system when the system is running and pressurized, the feed pump will cavitate and water flow will stop. This will not damage the system. Open the pressure relief valve and reprime the feed pump.

All reverse osmosis watermakers are affected by water temperature and salinity. The **Spectra** operating pressures will rise with colder temperatures and/or higher salinity, and fall with warmer temperatures and/or lower salinity, but the product flow is affected very little.

Shutdown Procedures

When not in use, biological growth in the membrane is the leading cause of membrane fouling. A warm environment will cause faster growth than a cold environment. The following procedures assume a warm environment, such as in the Tropics.

Normal Shutdown,

Run system to fill the tanks. Check system for normal operation, then with the system running, move the flush valve to the “flush” position. Watch for the feed pressure to drop and re-stabilize, wait 30 seconds and then shut down the system. When turning off the system, listen for the Clark Pump to “shift” then immediately turn off the power. There is a small chance that the Clark Pump will be left in a stalled condition if it is shut down during a “shift”. Service the pre-filters and strainer if necessary. In moderate climates, the system can be left unflushed for one to two days. In hot conditions, flush the system after each use.

Storage Shutdown or "Pickling,"

The Spectra SC-1 Storage and Cleaning chemical is specially formulated for the Spectra system. Sodium bisulfite or metabisulfite should not be used as a preservative in the Spectra systems. Use of sodium bisulfite will attack materials used in the Spectra systems and void the warranty.

The SC-1 Storage Cleaning Compound has to be mixed at 1 Spectra container to 3 gallons of fresh water to have the proper solution. An average of 1.5 gallons of water is in the Spectra system. This water has to be figured in the mixture

1. Attach the service hoses to the face of the unit and direct them to at least a 2 gallon clean plastic or SS mixing container. Run the system normally and then flush. When the flush is complete but before the system is shut down, move the brine discharge valve to the “service” position and collect (1.5) gallons of fresh flush water through the discharge service hose into the container. Turn off the system and open the pressure relief valve 1/2 turn.
2. Mix one container of the SC-1 into the cleaning container. Re-check that the pressure relief valve is open. Turn the intake and brine discharge valves to the “Service” position then run the system for 10 minutes. **Do not run the system pressurized with pickling solution in it.** Light discoloring of the solution is acceptable.

Do not let skin, eyes, or lungs have any contact with the storage and cleaning chemical. If the solution becomes excessively discolored, mineral scale and live biological growth may be present and membrane cleaning is recommended. Refer to the membrane cleaning section for further instructions.

Shutdown procedures cont.

3. After 10 minutes, turn the brine discharge valve to the “Run” position. When the container is empty, shut off the system.
4. Close the intake thru-hull and turn the intake service valve back to the “Run” position. If the system shares an intake thru-hull, move the intake service valve lever to the “Off” position. This will close off all ports and isolate the watermaker.

5. Remove and clean the sea water strainer screen and pre-filters. Reassemble dry.
6. When returning the system to service after pickling, check that the intake thru-hull open and service valves are in the “Run” position. Run ***unpressurized*** for at least 30 minutes to purge the system. Manually discard the product water for another 30 minutes after pressurizing.
7. To ***winterize***, Open the pressure relief valve and flush 5 gallons of potable water system antifreeze through the system instead of using the normal SC-1 storage procedures.

Maintenance

The Seawater Strainer

The sea water strainer's stainless steel element should be inspected, removed and cleaned as needed. Be careful to ensure that the thru-hull is closed before disassembly and the seal and element are in place on reassembly. When the system is put into storage, remove, rinse and reassemble dry to impede corrosion. Check frequently during operation.

The Micron Pre-filter

Service the pre-filter when the feed pressure is about 5 psi over normal for the conditions. The easiest way to service the filter is to first shut off the thru-hull, open the housing, discard the old filter, remove the O-ring to avoid loosing it, and clean the housing. Reinstall the O-ring and reassemble the pre-filter with a new 5-micron filter element. Leave dry until the next start-up.

Used pleated elements can be carefully cleaned if they are not too compacted. Do not use full pressure from a garden hose or scrub with a hard brush on the pleats. Gently spray the outside with water and then plug one end with your hand, filling from the other end to flush from the inside. Be careful to not distort the pleats. Another way is to tow them behind the boat until clean, 4 knots maximum. Slip a line through the filter and tie a stopper knot. Elements that show *any* signs of deterioration should be replaced. Check for leaks on the first run after a filter service.

The Charcoal Backflush Filter

Replace the charcoal filter element every 6 months.

The Membrane

The membrane needs to be cleaned only when it has lost up to 10% of its capacity due to fouling or the product quality degrades. The leading cause of fouling is from biological growth that occurs when the system is left unused for long periods without flushing or pickling. Fouling from mineral scaling can happen under certain sea water conditions, and from rust. Poor tasting water and/or higher than normal pressures and amp draw for the sea water temperature and salinity conditions are the main indicators of membrane fouling. Other conditions can cause high pressure (such as in very cold water). Low product flow is usually due to low voltage or a clogged pre-filter. Look for all other causes before cleaning the membrane.

There are two types of cleaners; acid and alkaline. The acid cleaner (SC-1) will remove mineral scaling and kill live microbes and is also used for storage. The alkaline cleaner (SC-2) is used to remove biological by-products, oil, and dirt particles that get past the pre-filters. If membrane performance is reduced and has not been pickled recently, cleaning with both chemicals is recommended. The acid cleaner should be used first. The acid cleaner is also used as the storage solution so scale is automatically reduced when the system is "pickled". If biological growth is suspected, the alkaline cleaner can be used on the next start up after the unit has been pickled.

If the membrane fails to respond to both cleanings, this is an indication of another problem with the system, or that it is time to replace the membrane. Call **Spectra Watermakers** before removing a membrane.

Membrane Cleaning

For normal cleaning, the SC-3 Acid Cleaning Compound is used first, then the SC-2 Alkaline Cleaning Compound. If known bio-fouling is present, the SC-2 may be used first. Using hot water if possible, 120°, is highly recommended as it greatly enhances the ability of the cleaners to do there jobs.

If the history of the system is unknown or has been left “unpickled” for an extended length of time and biological growth is present, it is recommended that the system is cleaned with the SC-2, using an alternate source of unchlorinated fresh water before the system is run under pressure. A simple test can be performed to see if biological growth has occurred: Before running the system, remove the pre-filters and examine their condition. If the housings are full of discolored smelly water, the system was not properly stored. Install clean pre-filters if they were bad. Next check the membrane. Attach the brine discharge service hose and lead to a container. Open the pressure relief valve 1 turn and turn the brine discharge service valve to the “Service” position. Manually run the system for 30 seconds. Examine the brine water; if it’s discolored and smells bad, perform a SC-2 cleaning with an alternate source of unchlorinated water before running the system pressurized. If the brine is fairly clean, the system can be purged, run normally, and checked for performance. Clean the membranes only if performance is reduced.

Heating the water is preferable. One way to do this is find a camp stove and use a large SS pot to heat the solution in. The cleaning solution throughout the system will heat as it circulates in and out of the pot. An alternative is to heat the one or two gallons of initial water in the cleaning container to 120° F on the main stove before mixing in the cleaner and circulating it into the system. Periodically stop and reheat the solution.

Perform the cleaning procedures while the ship is in acceptable sea water for purging and testing.

Cleaning Procedures

Note: procedures are the same for the SC-3 and SC-2 cleaners

A Spectra Cleaning Compound (SC-2 or SC-3) must be mixed with fresh water at a ratio of 1 Spectra container to 3 gallons to have the proper solution. An average of two gallons of water is in a 400 system or 4 gallons in a 1000 system. This water has to be figured in the mixture. A 400 system uses one cleaner container, a 1000 system uses two containers. SC-3 and SC-2 are never mixed together. Do not use them for storage.

Warning! The pressure relief valve on the Clark pump must be open for this procedure or membrane damage may result. Maximum pressure 50 psi.

Note: Triple the run/soak times if the solution is not heated

- Attach the service hoses to the pump/valve module and direct them to the cleaning container. Make sure the domestic water pressure system is on then start the automatic flush system. When the flush cycle stops, move only the brine discharge to the “Service” position and restart the flush cycle. Allow one gallon (400 system) or two gallons (1000 system) of flush water to flow into the container, then stop the system with the Start/Stop button. **Do not use tap water or chlorinated water!** Distilled or charcoal filtered water is acceptable if using the flush water is not an option.

Membrane Element Replacement

Do not remove the membrane from the housing unless absolutely necessary. Troubleshoot for all other causes of poor performance and try the recommend procedures first.

Caution: membranes must be kept wet to prevent permanent damage.

Disassembly:

Disconnect the high pressure tubes, cut the housing mount bands, and move the membrane housing to a work area that can handle water spillage. Clean off any deposits on the ends with a stiff brush and fresh water. Note which end goes where so they can be reinstalled the same way later.

Loosen the retainer rings with an adjustable deck fill fitting wrench or use a hard plastic or wood punch and a mallet on the slot provided. As the retainer rings unscrew, twist and pull the end fittings to follow the rings out. This way they can be removed with the factory plumbing fittings in place. By first removing the plumbing fittings, the rings can be removed and then the end plugs removed from the housing. Inspect the end plugs and O-rings for damage, replace if necessary.

Push the membrane element out of the housing by first pushing on the outlet end. If it resists, try pushing on the other end. If the membrane is going to be kept for any reason, seal it in plastic before it dries out. Do not open the new membrane packaging until ready to install.

Assembly:

Install the *inlet* end plug first. Lubricate the O-rings and the housing with soap or with a very thin layer of a pure silicone lubricant and start threading on the ring end plug assembly. As the end fitting O-ring comes into contact with the housing, twist and push on the end fitting to properly insert the O-ring, then continue tightening the retainer ring. If the tube fittings were removed, lubricate and insert the end plug then install the retainer ring and the plumbing fittings. Check that the new element has a brine seal on one end only. Lubricate the element brine seal and wet the whole inside of the housing. Insert the brine seal end of the element into the *outlet* end of the housing. A gentle push with a slight rocking motion and help with fingers should compress the brine seal lip so it slips inside. Push the element into the housing, the brine seal will give some resistance, until it completely engages the inlet end plug. The element product catch tube engaging and passing through the small O-rings can be felt. The element brine seal should now be next to the *inlet* plug.

Install the outlet end plug the same way as the inlet. It will go in harder because of the product tube O-ring engaging the element.

A new membrane has a pickling solution in it and should be thoroughly flushed before use. Follow the new system start up procedures.

Open the pressure relief valve 1/2 turn and start the system. Look for leaks at the end plugs. If a large leak is present, the large O-ring around the end plug is not seated properly and the end plug will have to be removed and redone. After flushing, close the relief valve and check system for proper operation.

Installation Basics

The **Spectra Watermakers** are designed for energy efficiency. All aspects of the system have been optimized for this goal, therefore any changes in the basic layout or components will most likely reduce this efficiency. The overall length of the feed, discharge and high pressure hoses have little effect on performance and can even help smooth out the Clark Pump shift pulses but that every hose bend or 90 degree fitting absorbs power. Avoid adding 90 degree fittings. Use gentle hose bends where possible. A good installation will be a proper compromise between minimum hose and wire runs, accessibility, environment and esthetics.

Thru-hulls

It is recommended that a designated 3/4" intake thru-hull and seacock be installed for the system as far below the water line as possible. A protruding scoop type is preferred for high speed hulls. Sharing a thru-hull with another system is acceptable, but can introduce unforeseen problems such as intermittent flow restriction, air bubbles and contaminates. If the system is sharing an intake thru-hull, the intake service valve can be used to shut off water to the system. For racing boats a retractable snorkel type thru-hull fitting is preferred to be able to pick up water away from the hull.

Do not install the intake close to or down stream of a head discharge. Install as far below the water line and as close to center line as possible to avoid contamination and air induction.

We recommend that a reputable boatyard install any underwater thru-hulls.

The discharge thru-hull should be mounted above the waterline, in or just above the boot stripe to minimize water lift. Having the discharge feed into a cockpit or sink drain will work, but can make an unpleasant gurgle sound.

Double clamp all hose connections below the water line if possible.

Fittings

Pipe fittings that are to thread into plastic should be coated with at least 3 wraps of Teflon tape. To avoid cracking the plastic, tighten until only 1/2 of the threads are buried. This may not seem tight, but they will not, and should not, bottom out like a metal to metal connection.

Metal to metal pipe connections should have 1-1/2 to 2 Teflon wraps only.

Be very careful to avoid getting any tape over the end of the fitting that might get into the system. To insure this does not happen, leave the very first thread uncoated.

General Plumbing

Follow the Clark Pump and Plumbing Diagrams on pages 26, 27, and 29 for hose and tube connections. All feed and discharge hoses are made of 5/8" reinforced nylon. The high pressure 1/2" tubing is connected with tube to pipe SS compression fittings. The 90 degree high pressure SS tube fittings mounted in the high pressure inlet and outlet on the Clark Pump can be **rotated** up to 1/2 turn for better tube runs. Straight SS tube fittings can also be used. The product water lines are 1/4" black plastic tubing with connectors. Feed water operating pressure up to 125 psi requires **vigorous** hose clamp tightening. It is recommended to lubricate the clamp screw and use a nut driver for the final tightening. **Re-tighten** all hose clamps and check for leaks after the first few hours of running.

If you use feed hose or product tubing that is not supplied by **Spectra Watermakers**, it is mandatory to use products with a **minimum burst pressure of 250 psi**. If other types of pre-filter housings are used, they need to be rated at 125 psi minimum working pressure.

Feed and Discharge Hoses

Route the 5/8" hose smoothly from the intake thru-hull to the strainer, main module, Clark pump, back to the main module, and then to the discharge thru-hull. Use straight hose fittings and gentle turns in the hose where possible. **Minimum hose bend radius is 6"**. Tightly secure hoses with tie wraps to avoid chafe.

Main Module Plumbing

The sea water intake hose connects to the hose barb in the upper port of the intake service valve. The feed water hose to the Clark Pump connects to the hose barb next to the accumulator tank. The brine discharge hose from the Clark Pump connects to the hose barb attached to the back port of the brine discharge valve. The brine discharge hose to the through hull connects to the hose barb in the front port of the brine discharge valve. The product tube from the membrane connects to the fitting at the bottom of the product flow meter. The product tube to the tank connects to the fitting in the top port of the product service valve. The fresh water flush hose runs from a tee installed in the feed line from the water tank to the hose barb on the flush filter.

High Pressure Tubes

Be sure to follow the Clark Pump and Plumbing Diagrams for proper connection between the Clark Pump and the membrane housing. Membrane water flow direction is marked on the housing. **Rotate** the 90 degree high pressure tube fittings on the Clark Pump for ideal tube runs. The high pressure tubes are usually made in place. Loosely route the tubes between the Clark pump and the membrane and cut long. Minimum tube bend radius is 6". **Follow the tube connection instructions on page 31**. Connect the tubes to one of the components, secure the tube runs, and then trim and connect to the other component. A 90 degree bend in a hose is better than a 90 degree fitting. A tube, when mounted, should have at least **one gentle bend** to allow for expansion. Do not connect a tube straight between hard mounted fittings. When connecting the tubes to the components, be sure to hold fitting body during the final tightening.

General Plumbing, cont.

If other than the Spectra supplied high pressure tube and fittings are used, they need to be at least 1/2" ID if hose, 1/2" OD if tube, with non-ferrous 1/2" high pressure fittings, and have a working pressure of at least 2000 psi.

Product Water Tubing

The product water lines are 1/4" plastic tubing. Minimum tube bend radius is 3." Connection can be made to either end of the membrane housing. ***Refer to the tube fitting assembly diagram on page 32. IMPORTANT: The product water flow should not be restricted in any way. If the line gets blocked, the pressure will build until the line fails. Restricting the flow will reduce efficiency and may cause damage to the membrane.*** Connect to the water tank at or near the top. The ideal spots are to tee into the tank vent line or the fill hose. Do not tap into the bottom of the tank or a water feed manifold. Air can be pulled through the membrane and affect the domestic water system.

Fresh water flush system

Install a tee into the feed line from the water tank to the ships water pressure pump inlet. Use the 5/8" feed hose to connect from the tee to the charcoal flush filter.

Fittings

Pipe fittings that are to thread into plastic should be coated with at least 3 wraps of Teflon tape. To avoid cracking the plastic, tighten until only 1/2 of the threads are buried. This may not seem tight, but they will not, and should not, bottom out like a metal to metal connection.

Metal to metal pipe connections should have 1-1/2 to 2 Teflon wraps only. Be very careful to avoid getting any tape over the end of the fitting that might get into the system. To insure this does not happen, leave the very first thread uncoated.

Component Placement

Refer to the Dimension & Plumbing Diagrams on pages 26 to 29

Main Pump and Control Module

The main pump module is designed to mount on a vertical surface. The feed pump level can be up to 4' above the waterline. Locate in an area that allows easy access to the face panel and the service hoses can reach a container placed in a spot where water spillage is acceptable. Allow for a minimum of 2" of clearance on the sides and top. Use the unit itself as a template for drilling the mounting bolt holes. Use quarter inch bolts or lag screws with washers. If lag bolts are used they must thread into at least 1" of solid material. Drill pilot holes for lags bolts. If necessary additional mounting holes can be easily drilled into the back panel.

Clark Pump

Refer to the the Clark Pump Mounting Diagram on page 30 to install the mounting brackets and shock mounts. Bolt the mounting brackets to the base of the center block with the short 5/16" SS bolts and washers, sandwiching the plastic washers in between the center block and the brackets. The brackets will over hang from the front and back of the center block. Moisten the rubber shock mounts and slip them into the bracket holes then install the plastic inserts.

The Clark Pump can be mounted on any horizontal surface that will support it's weight and is not subjected to excessive vibration. Height above or below the water line is unrestricted. Mounting on a vertical surface can be expedited by using the optional "L" mount bracket. For hanging from overhead, use two of the "L" brackets. Avoid mounting in the middle of a large unsupported flat surface that could amplify the sound of the pump shift. The Clark Pump can be mounted in any position if it is hard mounted without using the brackets. More noise may be transferred to the vessel.

Allow room in the front and back for access to the high pressure tubes and hose connections. If the space behind the unit is restricted, attach the high pressure tubes to the Clark Pump before final mounting. The 90 degree fittings supplied are acceptable for the feed and high pressure tube connections to the unit and can be rotated for easy tube runs. Straight fittings can also be used. The brine discharge hose connection to the reversing valve body should be straight if possible, and can be connected to either end of the reversing valve. Plug the unused port.

Make sure that the area around and under the pump does not have any water sensitive equipment. Water will be spilled during any repairs or if a leak occurs.

Use the Clark Pump mounting hole layout, see page 33, to measure and drill for the fasteners. 1/4" bolts and Nylock nuts are preferred, but lag bolts are acceptable if they penetrate at least 1" into solid material. Drill pilot holes for lags bolts.

Caution: Tighten the fasteners until there is medium pressure on the plastic inserts. The plastic inserts will collapse if over tightened. The 1/4" fender washer must be on top to prevent the mounting brackets from slipping out of the rubber mounts under adverse conditions.

Do not mount the Clark Pump in an area that is subject to sustained temperatures over 120 degrees F.

Component Placement, cont.

Membrane and Housing Assembly

Mount the membrane and housing assembly as close to the Clark Pump and in as cool a place as possible. Use the black plastic brackets and heavy duty black tie wraps provided. The plastic tie wraps allow the membrane housing to expand and contract with pressure changes without damage. Mount the membrane preferably at or below the level of the valve body on the Clark Pump to help purge air. It is OK to mount the membrane above the Clark Pump, but keep it as close as possible. The membrane housing is marked for water flow direction and can be mounted at an angle or vertical, but the ***brine outlet end should be up to help purge air***. Route the high pressure tubing to and from the membrane housing as smoothly as possible. Avoid clamping the tubes tightly to any surfaces for sound dampening. "Hanging" the tubes away from a surface with wire ties so that they are neither tight nor completely loose is best.

The product water tube can be connected to either end of the membrane. Plug the unused product port and re-label.

Do not mount the membrane in an area that is subject to sustained temperatures over 120 degrees F.

Sea Water Strainer

Mount the sea water strainer between the intake thru-hull valve and the main module in a protected, accessible and visible spot that is not above water sensitive equipment. Secure it with the black plastic mount and tie provided. Allow a minimum of 1-1/2" space below for the strainer bowl removal. Note the direction of flow on the housing and mount to minimize hose lengths and bends.

Accumulator Tank

When the Santa Cruz is ordered with the duplex feed pump option the accumulator is mounted separately from the main module. Mount it in any convenient spot, at any orientation, plumbed between the pre-filter and the Clark Pump.

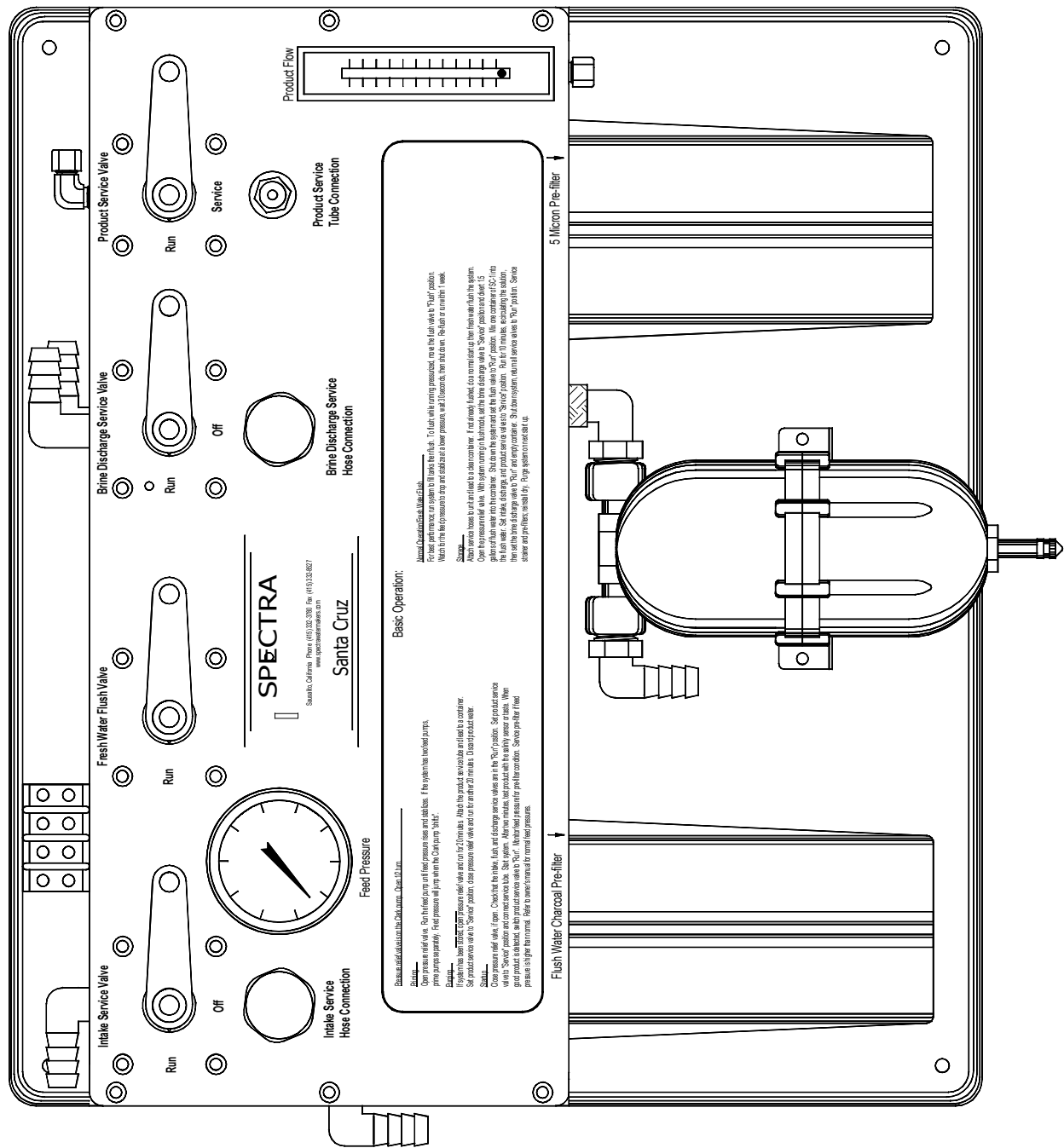

Santa Cruz Main Module

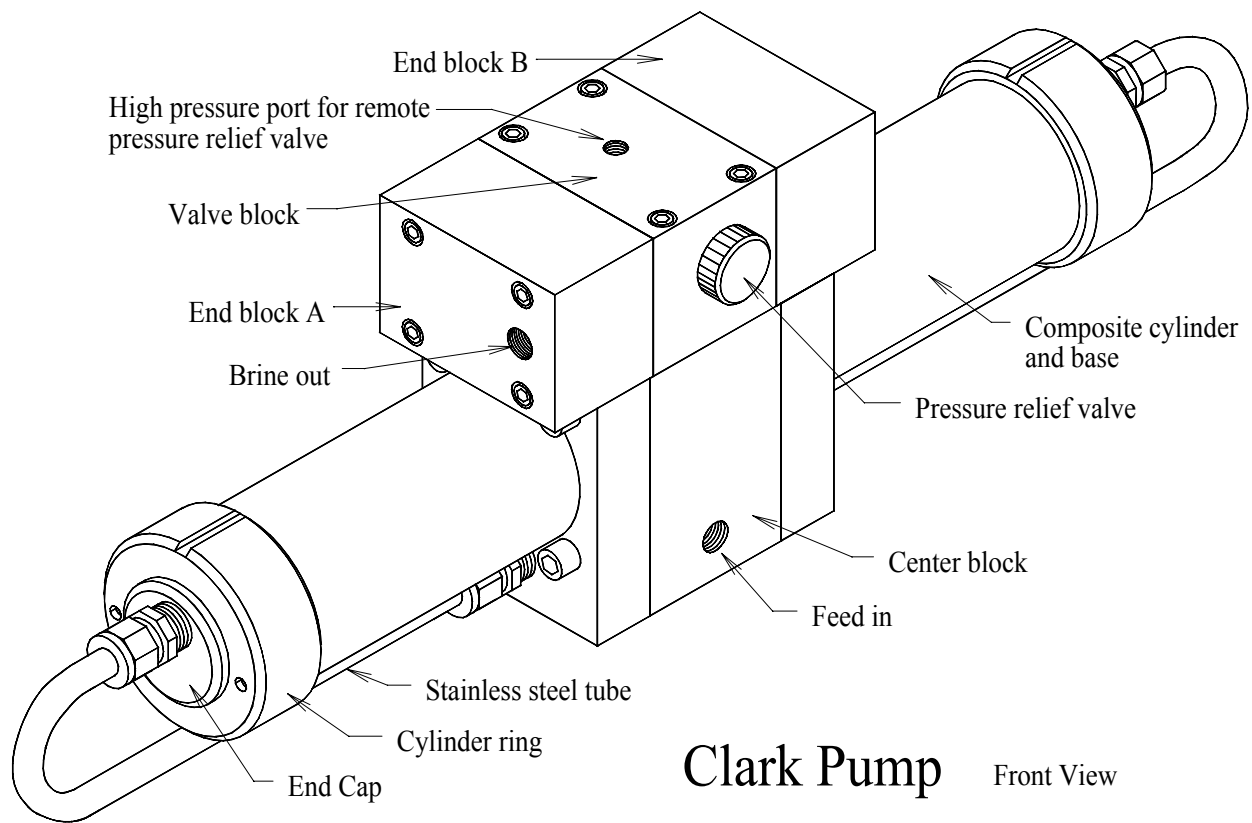

Clark Pump Front View

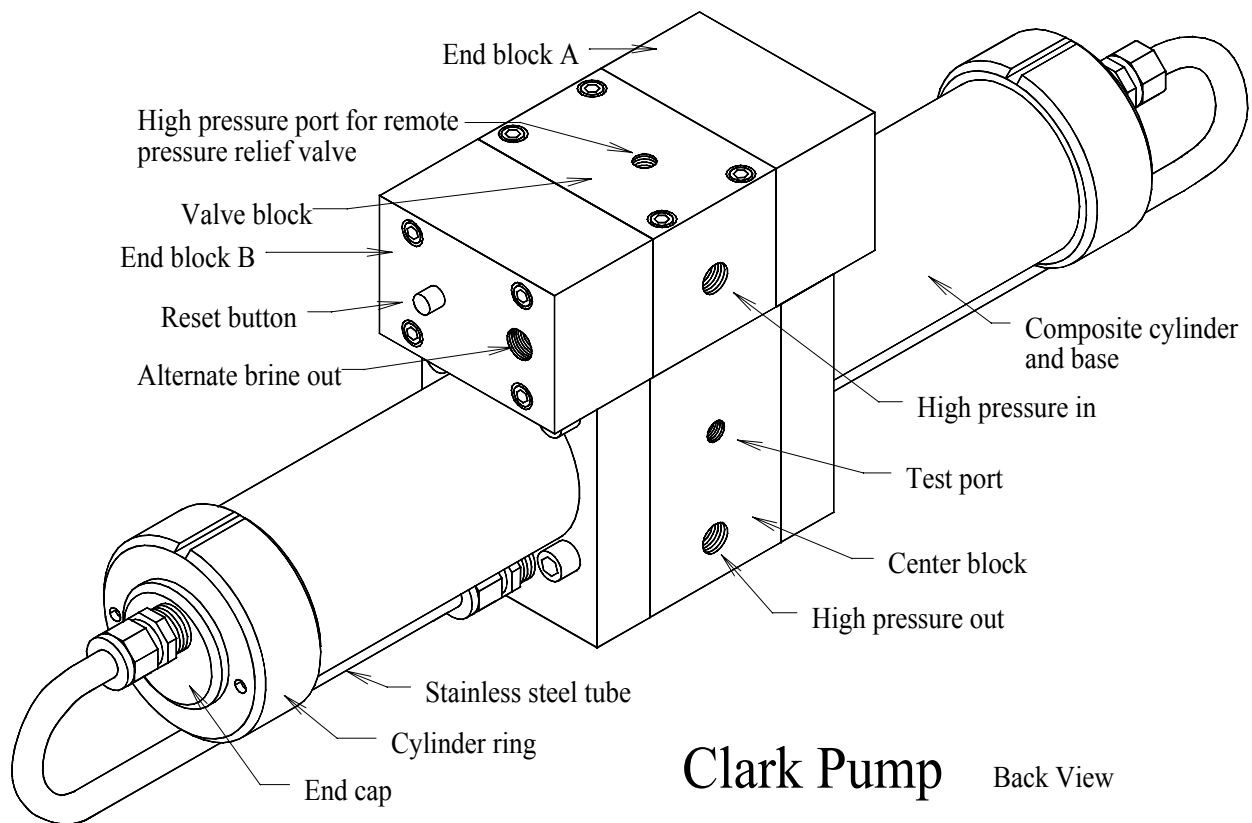

Clark Pump Back View

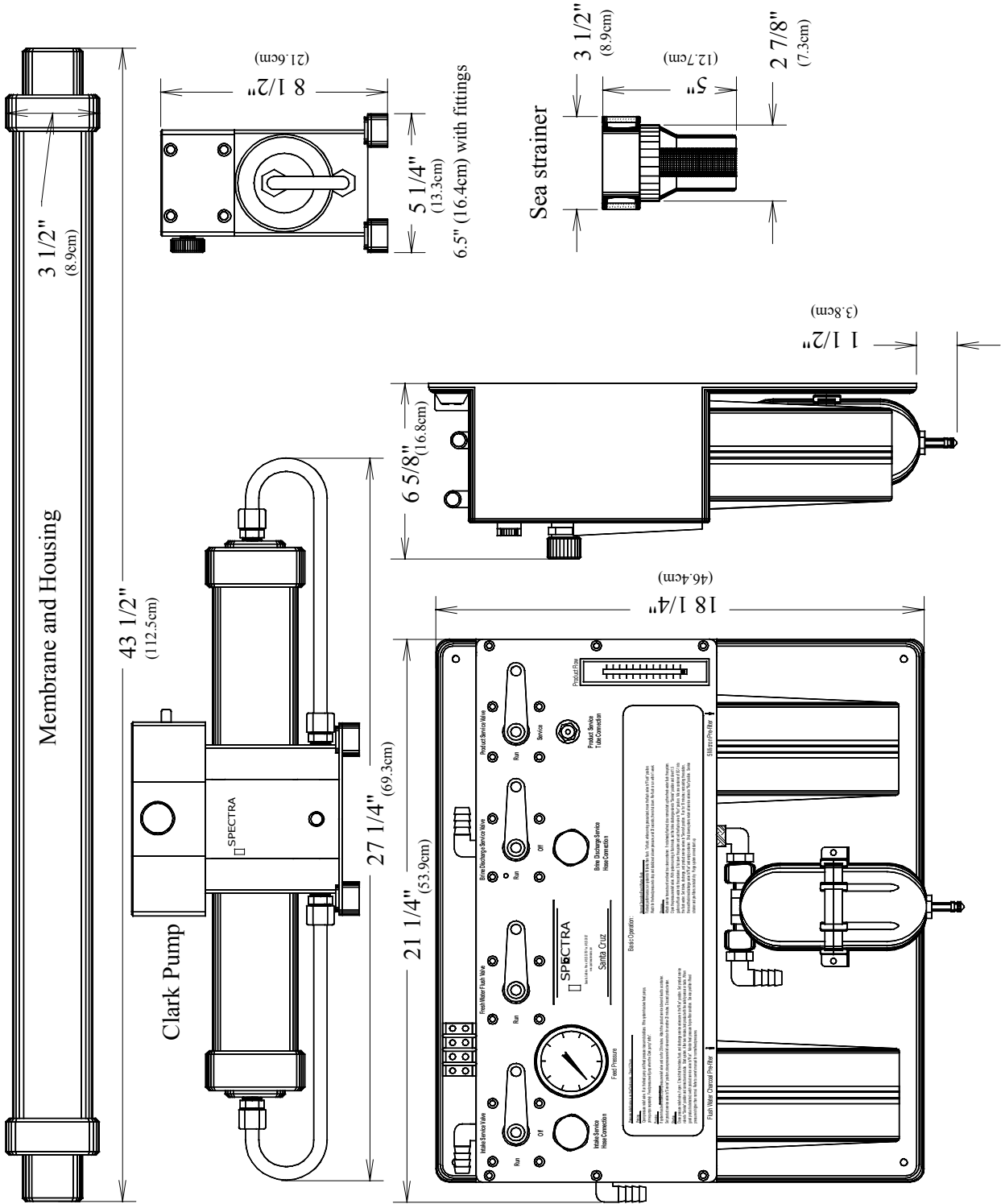

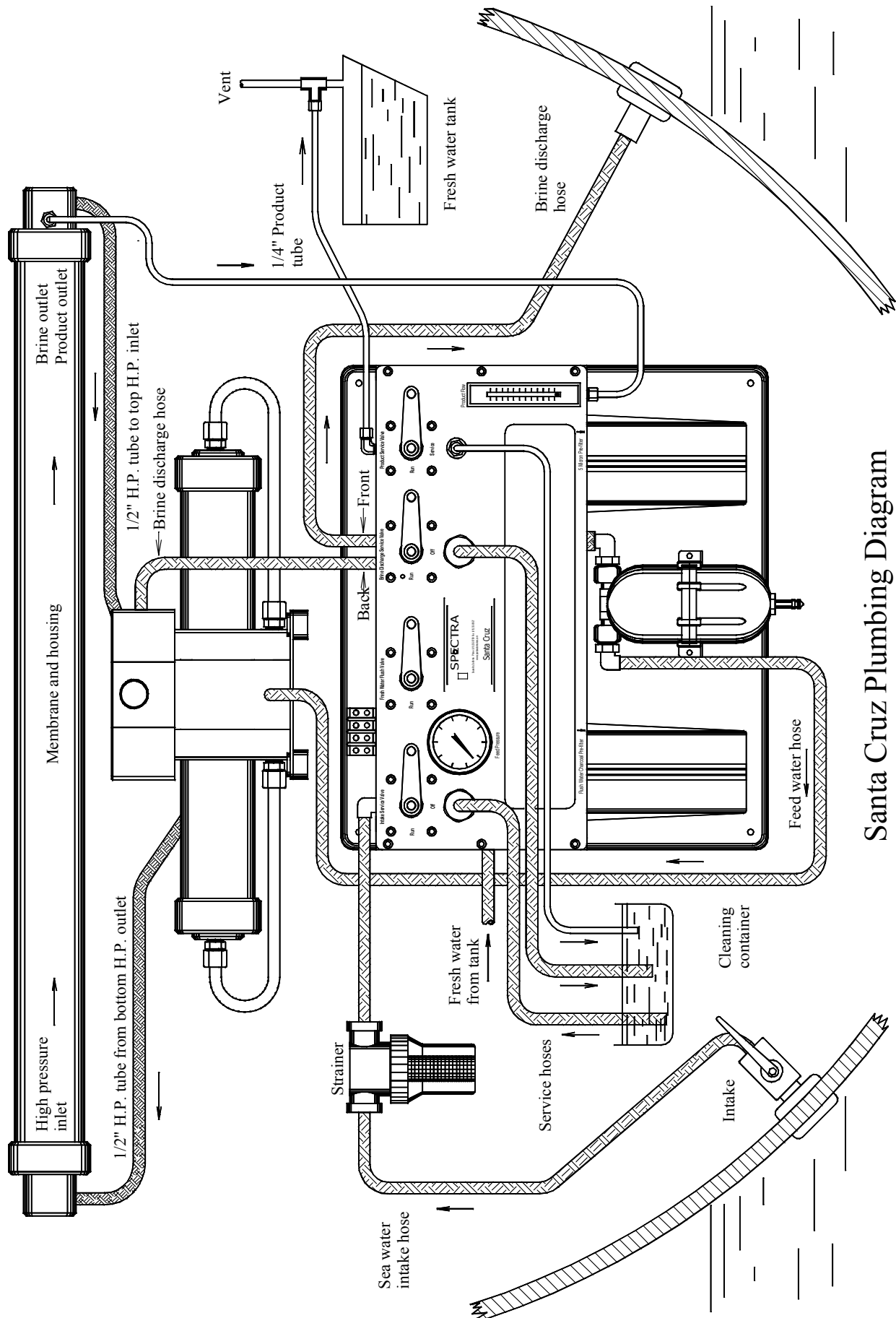

Santa Cruz Plumbing Diagram

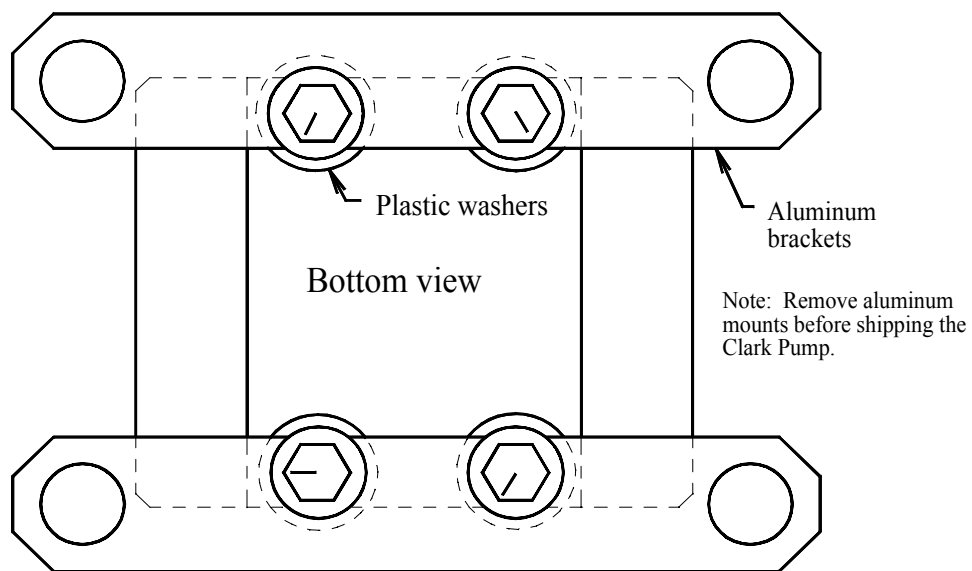
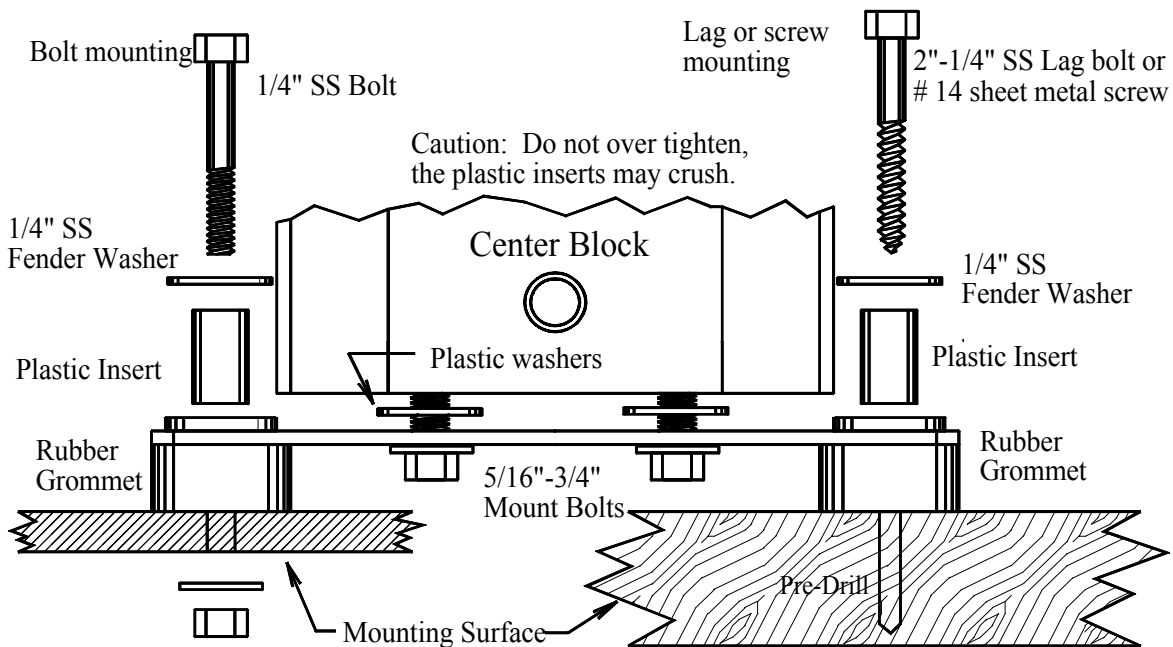

Clark Pump Mounting

Spectra High Pressure Tube Fitting Assembly

Carefully fit and measure the tubing before cutting with a sharp razor knife or hose cutter and remove any burrs. Minimum tubing bend radius is 6". Route tubing away from excessive heat sources and secure from vibration and chafe. Have at least one shallow bend in a tube assembly after it is installed.

Refer to figure 1. If a fitting has been disassembled, reassemble as illustrated. The notch on the ferrule must engage the inside of the nut properly for the nut to seat down fully. Once the tube is inserted the ferrule and nut will naturally align.

Refer to figure 2. Insert tube fully into the fitting, it should go in 0.9". Tighten the nut finger tight while moving the tube around to prevent binding. One thread should be showing under the nut. Secure the tube so it won't back out when tightening.

Refer to figure 3. Use 13/16" wrench to hold a straight body fitting or a 3/4" wrench for a 90° body, and a 7/8" wrench for the nut. Hold the body, recheck the tube insertion, then tighten the nut 1-2/3 turns (10 flats) after a good finger tight. Use the index mark on the nut as a guide. The threads should be completely covered by the nut.

The tube connectors can be disconnected and re-tighten several times. To reconnect, insert the tube and ferrule into the body then hand tighten the nut. Hold the body and tighten the nut with a wrench a little past where resistance is encountered. When correct, the nut should be tightened a little past where it was before disassembly. Always check for leaks.

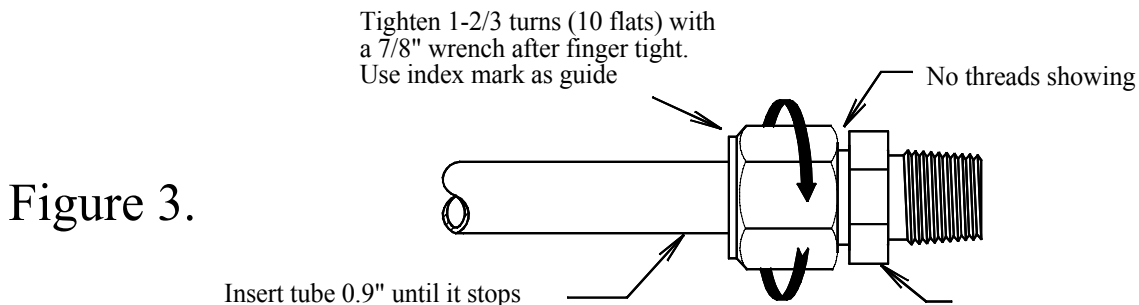
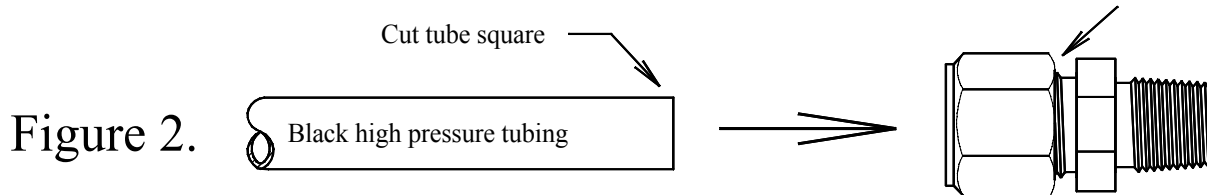
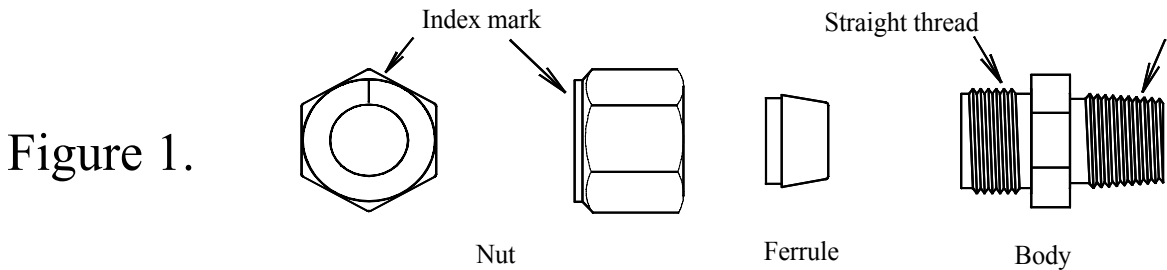

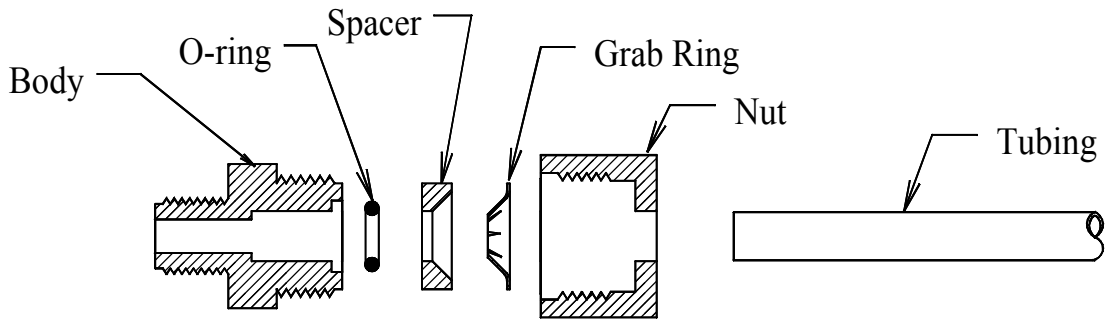

Step 1: Disassemble fitting components

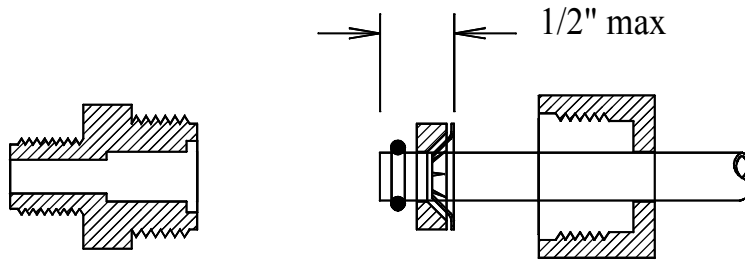

Step 2:

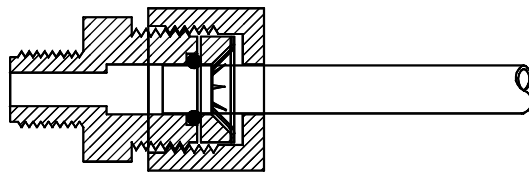

Step 3: Gently fit the tube into the body and loosely thread on the nut.

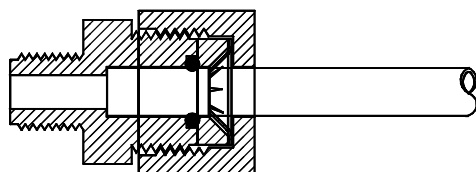

Step 4: Push the tube into the body until it bottoms out then hand tighten the nut.
DO NOT OVER TIGHTEN!

1/4" Tube Fitting Assembly

Drill for 1/4" bolts,
1/4" lags,
14 SM Screws

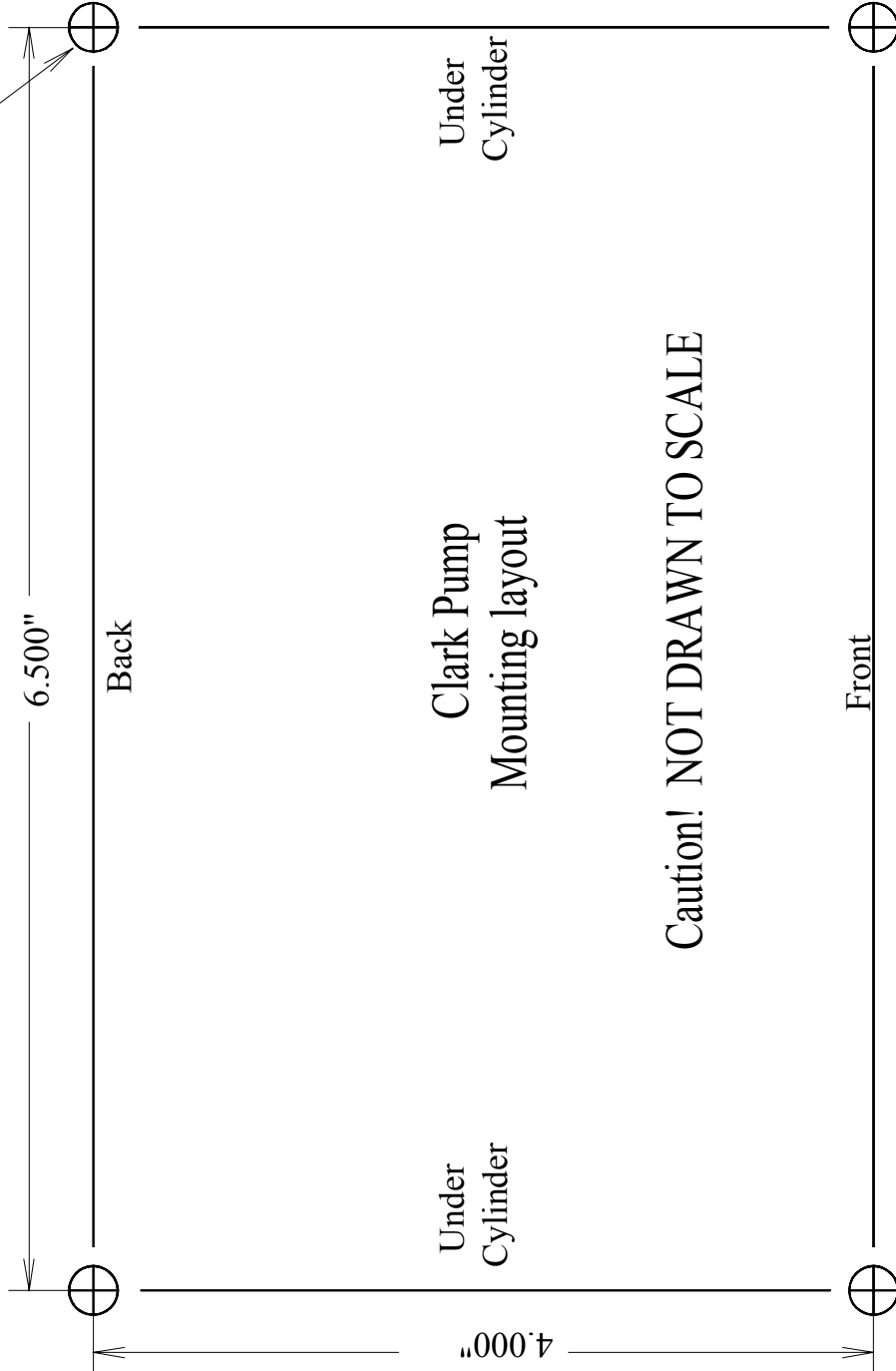

6.500"

Back

Clark Pump
Mounting layout

Under
Cylinder

Under
Cylinder

Caution! NOT DRAWN TO SCALE

Front

4.000"

ELECTRICAL

See the wiring diagram on the following page.

A robust electrical connection is crucial to the proper operation of the system. Examine your electrical system carefully to determine the proper place from which to draw power. If power will be drawn from a breaker on the main distribution panel, make sure the panel has at least #8 gauge wire for panel positive feed *and* ground. Check all connections for tightness, including the ground buss. ***Refer to the wiring diagrams on page 35.***

If the panel is inadequate or too far away, a direct connection to a battery is possible. An in-line fuse (15 amp-slow blow) next to the battery and a switch (20 amp minimum rating) will be necessary. For 24 VDC systems use a 7.5 amp breaker.

Main module wiring: For 12 VDC use a 15 amp breaker, 24 VDC use 7.5 amp breaker. Wire from the power source to the module using #12 gauge to 10 feet, #10 gauge to 18 feet, and #8 gauge to 28 feet. For 24 VDC systems use a 15 amp breaker and #14 gauge to 10 feet, #12 gauge to 18 feet, and #10 gauge to 28 feet.

Use marine grade insulated double-crimp connectors that match the wire gauge. Size ring terminals to the size of the fasteners. Crimp the connectors with a crimper designed for insulated connectors using *both* hands as hard as you can for the main crimp, and a little easier for the insulation crimp. Pull on the connector to test the strength of the crimp, you should not be able to pull it off. Heat shrink all connections where possible. Remember to slip the heat shrink onto the wires before crimping.

Follow the pattern of the original factory wiring when adding a new circuit. When adding a new wire to an existing wire bundle, remove all the old tie wraps where possible, run the new wire, then tie at even intervals. This will result in a clean and "original" look.

Connect the power wiring to the terminal block on the top of the back panel, + red, - black.

Troubleshooting Guide

Spectra Santa Cruz Wiring Diagram

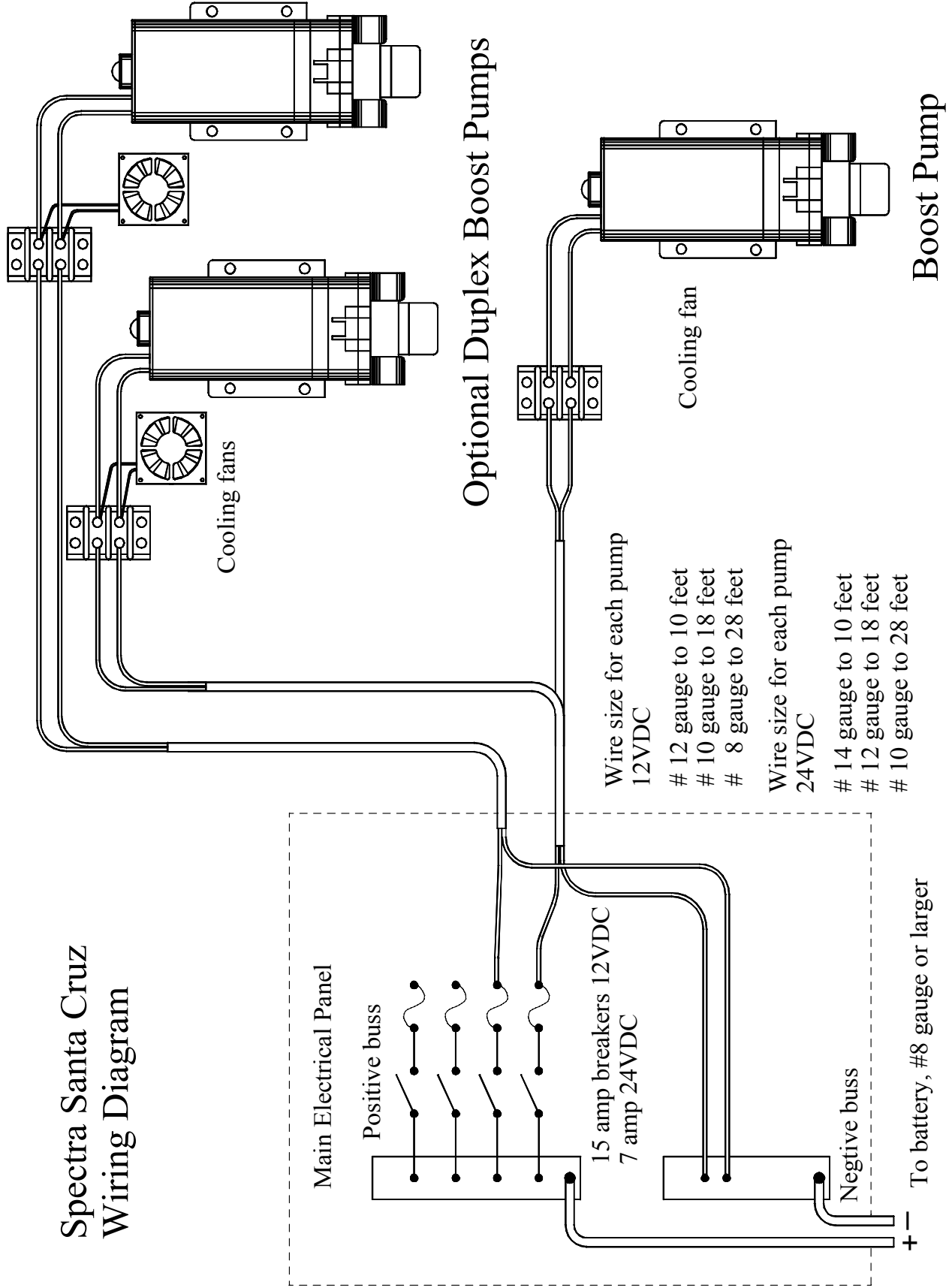

For instructions on repairing the Clark Pump, please contact **Spectra Watermakers**.

SYMPTOM	CAUSE	REMEDY
*Feed pump start but shuts down on high pressure. (over 100 psi)	*Clark Pump stalled. *Brine service valve in mid (off) position *Pre-filters excessively clogged	*Push in reset button *Open brine service valve *Service pre-filters
*System does not run	*Tripped breaker or blown fuse. *Pump power relay faulty. *Motor burned out.	*Check wiring to motor. *Replace relay. *Replace motor.
*Feed pump runs but no fresh water flow.	*Thru-hull closed. *Pressure relief valves open. *Pump air-locked.	*Check system, then open thru-hull. *Close relief valves. *Open relief valve to purge air, then close.
*Lower water production, high amp draw, high feed pressure.	*Pre-filter clogged.	*Service pre-filters.
*Low water production, normal to low amp draw, normal to low feed pressure.	*Relief valve partially open. *Leak in high pressure hoses or fittings. *Internal leakage in the Clark Pump. *Debris in feed pump check valves.	*Tighten hand tight only. *Tighten or replace fitting and/or hose. *See Clark Pump Repair Manual. *Disassemble pump head and clean.
*Water production normal, feed pressure high, high amp draw.	*Cold sea water temperature. *Membrane starting to foul.	*Normal operation. *Clean membrane.
*Water production normal, feed pressure low, amp draw low.	*Warm sea water temperature.	*Normal operation.
*Water production high, poor water quality.	*Seal failure inside membrane housing. *Membrane failure.	*Disassemble and check for bad seals and/or corrosion. *Replace membrane.
*Asymmetrical pressure and flow readings between shifts.	*Reversing valve seal leaking. *Shaft seal leaking. *Pin seal leaking. *Check valve leaking. *Scored cylinder wall. *Piston seal leaking.	*See Clark Pump Repair Manual.

LIMITED WARRANTY

Spectra Watermakers warrants to the original purchaser that all components, except for the Clark Pump, are free from any defects in material and/or workmanship for a period of one year from the date of purchase.

Spectra Watermakers warrants to the original purchaser that the **Clark Pump** is free from any defects in material and/or workmanship with a limited life time warranty from the date of purchase.

If any such defect is discovered and reported within the warranty period, **Spectra Watermakers** will repair or replace the affected component free of charge, subject to verification of the defect or malfunction upon inspection at **Spectra Watermakers**. The customer is responsible for all costs incurred for removal, shipping to and from our facility, and reinstallation.

This warranty *does not* apply to malfunctions or physical damage resulting from abuse, neglect, accident, alteration, modification, feed pump substitution, submersion, shipping damage, hoses and fittings not supplied by **Spectra Watermakers**, improper membrane maintenance, oil and chlorine damage, use of sodium bisulfite or sodium metabisulfite, or improper installation. Consumables such as pre-filter elements are not covered.

Spectra Watermakers, under no circumstances, shall be liable for any consequential damages arising out of, or in any way connected with, the failure of the product to perform as set forth herein. This limited warranty is in lieu of any and all other expressed or implied warranties.

Spectra Watermakers reserves the right to make changes or improvements on its products without incurring the obligation to retrofit such changes or improvements on previously manufactured units.

If a possible warranty problem is detected, please contact one of our service representatives *before any disassembly* for assistance, and to receive a Return Authorization number if a component is to be returned for a warranty repair.

Proof of purchase, return address, and a Return Authorization number are required for all warranty repairs.

Ship to:

Spectra Watermakers
298 Harbor Drive Sausalito, CA 94965

Phone 415.332.3780 Fax 415.332.8527
E-mail: spectra@spectrawatermakers.com